

CLIFFORD®

Responder LE Model 3.3X Security and Remote Start

Installation Guide

Note: This product is intended for installation by a professional installer only! Any attempt to install this product by any person other than a trained professional may result in severe damage to a vehicle's electrical system and components.

Directed®
E L E C T R O N I C S

© 2008 Directed Electronics, Vista, CA
N5202X 2008-02

Bitwriter[®], Code Hopping[™], Doubleguard[®], ESP[™], FailSafe[®], Ghost Switch[™], Learn Routine[™], Nite-Lite[®], Nuisance Prevention[®] Circuitry, Revenger[®], Silent Mode[™], Soft Chirp[®], Stinger[®], Valet[®], Vehicle Recovery System[®], VRS[®], and Warn Away[®] are all Trademarks or Registered Trademarks of Directed Electronics.



The Bitwriter[®] (p/n 998U) requires chip version 2.5 or newer to program this unit.

Bitwriters with date code of 6C or older require an IC upgrade (p/n 998M). Bitwriter 2 compatible.



Table of contents

What is included	5
Warning! Safety first	6
Installation points to remember	8
Deciding on component locations	10
Finding the wires you need	13
Making your wiring connections	20
Primary harness (H1), 12-pin connector	21
Auxiliary harness (H2), 8-pin connector	21
Door lock harness, 3-pin connector	22
Heavy gauge remote start, (H3) 10-pin connector	22
Remote start input, 5-pin connector.	22
Remote start auxiliary output, 5-pin.	23
Wire connection guides	24
Primary harness (H1)	24
Auxiliary harness (H2)	30
Door lock wiring diagrams.	34
Heavy gauge, 10-pin connector	44
Remote start input-5-pin connector	45
Outputs for optional external remote start relays	47
Neutral safety switch interface	48
Plug-in LED and valet/program switch	51
Programmer interface, 3-pin black plug	51
Optional sensor port - 4 pin connector	52
Tach learning	53
D2D jumper settings	54
Setting the light flash polarity	55

Remote control learn routine.	56
Remote control configuration	58
System features learn routine	60
Feature menus	63
Feature descriptions	66
Nuisance prevention circuitry	76
Valet mode	77
Manual transmission remote start	78
Timer mode.	79
Long term event history	80
Table of zones	81
Shutdown diagnostics	82
Remote starting diagnostics.	83
Remote start safety check.	83
Troubleshooting	85
Quick reference wiring guide.	89

What is included

- The control module with Stinger™ DoubleGuard® two-stage shock sensor
- Control center (installed out of sight) with integrated status LED and Valet Override switch (p/n 6211T)
- One five-button/2-way Supercode Responder LE Remote Control, (p/n 7251X)
- One five-button /1-way Supercode Remote (p/n 7152X)
- Revenger™ Soft Chirp™ six-tone programmable siren
- A shut-down toggle switch

Warning! Safety first

The following safety warnings must be observed at all times:

■ Due to the complexity of this system, installation of this product must only be performed by an authorized Directed Electronics dealer.

■ When properly installed, this system can start the vehicle via a command signal from the remote control. Therefore, never operate the system in an area that does not have adequate ventilation. The following precautions are the sole responsibility of the user; however, authorized Directed Electronics dealers should make the following recommendations to all users of this system:

1. Never operate the system in an enclosed or partially enclosed area without ventilation (such as a garage).
2. When parking in an enclosed or partially enclosed area or when having the vehicle serviced, the remote start system must be disabled using the installed toggle switch.
3. It is the user's sole responsibility to properly handle and keep out of reach from children all remote controls to assure that the system does not unintentionally remote start the vehicle.
4. **USER MUST INSTALL A CARBON MONOXIDE DETECTOR IN OR ABOUT THE LIVING AREA ADJACENT TO THE VEHICLE. ALL DOORS LEADING FROM ADJACENT LIVING AREAS TO THE ENCLOSED OR PARTIALLY ENCLOSED VEHICLE STORAGE AREA MUST REMAIN CLOSED AT ALL TIMES.**

■ Use of this product in a manner contrary to its intended mode of operation may result in property damage, personal injury, or death. Except when performing the Safety Check outlined in this installation guide, (1) Never remotely start the vehicle with the vehicle in gear, and (2) Never remotely start the vehicle with the keys in the ignition. The user will be responsible for having the neutral safety feature of the vehicle periodically checked, wherein the vehicle must not remotely start while the car is in gear. This testing should be performed by an authorized Directed Electronics dealer in accordance with the Safety Check outlined in this product installation guide. If the vehicle starts in gear, cease remote start operation immediately and consult with the user to fix the problem immediately.

■ After the remote start module has been installed, test the remote start module in accordance with the Safety Check outlined in this installation guide. If the vehicle starts when performing the Neutral Safety Shutdown Circuit test, the remote start unit has not been properly installed. The remote start module must be removed or properly reinstalled so that the vehicle does not start in gear. All installations must be performed by an authorized Directed Electronics dealer. **OPERATION OF THE REMOTE START MODULE IF THE VEHICLE STARTS IN GEAR IS CONTRARY TO ITS INTENDED MODE OF OPERATION. OPERATING THE REMOTE START SYSTEM UNDER THESE CONDITIONS MAY RESULT IN PROPERTY DAMAGE OR PERSONAL INJURY. IMMEDIATELY CEASE THE USE OF THE UNIT AND REPAIR OR DISCONNECT THE INSTALLED REMOTE START MODULE. DIRECTED ELECTRONICS, INC. WILL NOT BE HELD RESPONSIBLE OR PAY FOR INSTALLATION OR REINSTALLATION COSTS.**

■ Remote starters for manual transmission pose significant risks if not properly installed and operated. When testing to ensure the installation is working properly, only remote start the vehicle in neutral gear, on a flat surface and with a functional, fully engaged parking brake. Do not allow anyone to stand in front of or behind the vehicle.

■ This product should **NOT** be installed in any convertible vehicles, soft or hard top. Installation in such vehicles may pose certain risk.

Installation points to remember

This product is designed for fuel-injected, automatic transmission, or vehicles with manual transmissions.

Note: The default option “Manual” is a safety precaution that forces the installer to enable the Manual Transmission Mode (MTS) routine or program the unit to the “Automatic” option before the remote start can be activated for the first time.

The “Automatic” option will need to be programmed On to work with automatic transmissions. When the “Manual” option is selected a specific routine is required before exiting the vehicle to enable the MTS mode.

Before beginning the installation

- Please read this entire installation guide before beginning the installation. The installation of this remote start system requires interfacing with many of the vehicle’s systems. Many new vehicles use low-voltage or multiplexed systems that can be damaged by low resistance testing devices, such as test lights and logic probes (computer safe test lights). Test all circuits with a high quality digital multi-meter before making connections.
- Do not disconnect the battery if the vehicle has an anti-theft-coded radio. If equipped with an air bag, avoid disconnecting the battery if possible. Many airbag systems will display a diagnostic code through their warning lights after they lose power. Disconnecting the battery requires this code to be erased, which can require a trip to the dealer.
- If using an external LED or Valet Switch, check with the customer about where to locate the switch.
- To avoid accidental battery drainage; turn off the interior lights or remove the dome light fuse.
- Roll down a window to avoid being locked out of the car.

After the installation

- Test all functions. The “Using Your System” section of the Owner’s Guide is very helpful when testing.
- When testing, don’t forget that this system is equipped with Nuisance Prevention® Circuitry (NPC). NPC can bypass trigger zones, making them appear to stop working. See the Nuisance Prevention® Circuitry section.
- Review and complete the Safety Check section of this guide prior to the vehicle reassembly.

Deciding on component locations

Siren

Some things to remember about mounting the siren:

- Keep it away from heat sources, such as radiators, exhaust manifolds, turbochargers, and heat shields.
- Mount it where a thief cannot easily disconnect it, whether the hood is open or shut. Both the siren and its wires should be difficult to find. This usually involves disguising the wire to look like a factory harness.
- We do not recommend grounding the siren to its mounting screws. Instead, we recommend running both the red and black wires into the passenger compartment and grounding to one common point for all devices. Both wires are the same length and come already bonded together to make it easier. Whenever possible, conceal your wires in the factory harnesses or in the same style loom as the factory.
- When possible, place the siren on the same side of the vehicle as the control module, where its wires will reach the control module's wires without extending them. Always run the wires through the center of a grommet, never through bare metal!
- Point the siren down so water does not collect in it.

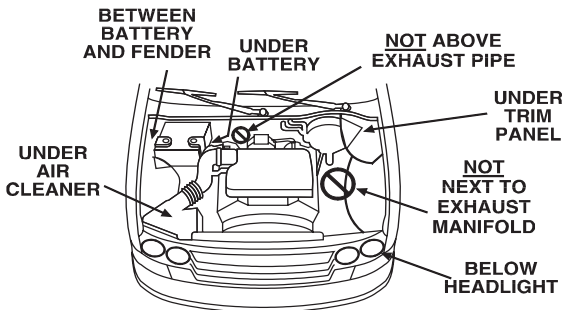

DRW-18

Control module

Some things to remember about where to mount the control module:

- Never put the control module in the engine compartment!
- The first step in hot-wiring a vehicle is removing the driver's side under-dash panel to access the starter and ignition wires. If the control module is placed just behind the driver's side dash it can easily be disconnected.
- When mounting the control module, try to find a secure location that will not require you to extend the harnesses' wires (they are 1.5 meters long). Keep it away from the heater core (or any other heat sources) and any obvious leaks.

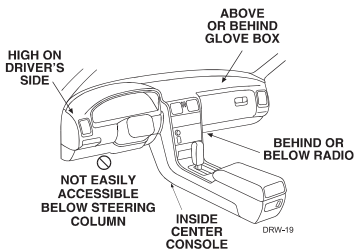

Some good control module locations are: Above the glove box, inside the center console, above the under-dash fuse box, or above the radio.

The control center

The control center position should be discussed with the vehicle's owner prior to installation. The LED and Valet switch is housed on the control center, so you will want to make sure that the customer is satisfied with the location.

Doubleguard shock sensor

Since the shock sensor is built into the main unit, be sure to keep the shock sensor performance in mind when deciding on a location for the main unit.

Note: In many vehicles, fastening the main unit (the brain) to a steering column or screwing it to metal will result in poor sensitivity, especially at the rear of the vehicle.

Valet® program switch

The valet/program switch is built into the control center.

Important! When the vehicle is delivered, please show the user where this switch is located and how to disarm the system with it.

Note: An optional valet switch (p/n #8631) is available if the onboard valet switch is not used for the install.

When installing the external valet switch ensure that the location has sufficient clearance to the rear. The switch should be well hidden. It should be placed so passengers or stored items (such as in a glove box or center console) cannot accidentally hit it. The switch fits into a 9/32-inch hole.

Status LED

The status LED is built into the control center. An optional LED (p/n 8634) is available if the onboard LED will not be used for the install. The LED fits into a 9/32-inch hole.

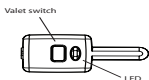

Finding the wires you need

Now that you have decided where each component will be located, you are ready to find the wires in the car that the security system connects to.

Important! Do not use a 12V test light or logic probe (computer safe test light) to find these wires! Use a digital multi meter for all testing.

Obtaining constant 12V

We recommend two possible sources for 12V constant: the (+) terminal of the battery, or the constant supply to the ignition switch. Always install a fuse within 12 inches of this connection. The fuse will also be powering other circuits such as door locks and interface modules, so fuse accordingly.

Important! Do not remove the fuse holder on the red wire. It ensures that the control module has its own fuse, of the proper value, regardless of how many accessories are added to the main power feed.

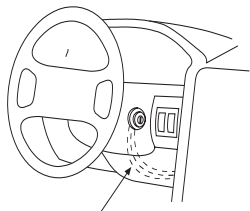
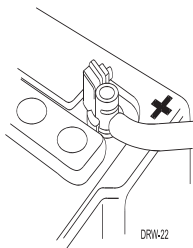
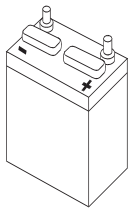

CONSTANT 12V DRW-23

12V switched ignition wire

The ignition wire is powered when the key is in the run or start position. This is because the ignition wire powers the ignition system (spark plugs, coil) as well as the fuel delivery system (fuel pump, fuel injection computer). Accessory wires lose power when the key is in the start position to make more current available to the starter motor.

How to find (+)12V ignition with your multi meter:

1. Set to DCV or DC voltage (12V or 20V is fine).
2. Attach the (-) probe of the meter to chassis ground.
3. Probe the wire you suspect of being the ignition wire. The steering column harness or ignition switch harness is an excellent place to find this wire.
4. Turn the ignition key switch to the run position. If your meter reads (+)12V, go to the next step. If it doesn't, probe another wire.
5. Now turn the key to the start position. The meter display should stay steady, not dropping by more than a few tenths of a volt. If it drops close to or all the way to zero, go back to Step 3. If it stays steady at (+)12V, you have found an ignition wire.

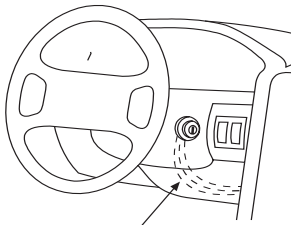

Starter wire

The starter wire provides 12V directly to the starter or to a relay controlling the starter. In some vehicles, it is necessary to power a cold start circuit. A cold start circuit will test exactly like a starter circuit, but it does not control the starter. Instead, the cold start circuit is used to prime the fuel injection system for starting when the vehicle is cold.

How to find the starter wire with your multi meter:

1. Set to DCV or DC voltage (12V or 20V is fine).
2. Attach the (-) probe of the meter to chassis ground.
3. Probe the wire you suspect of being the starter wire. The steering column is an excellent place to find this wire. Remember you do not need to interrupt the starter at the same point you are testing.
4. Turn the ignition key switch to the start position. Make sure the car is not in gear! If your meter reads (+)12V, go to the next step. If it doesn't, probe another wire.
5. Cut the wire you suspect of being the starter wire.
6. Attempt to start the car. If the starter engages, reconnect it and go back to Step 3. If the starter does not turn over, you have the right wire.

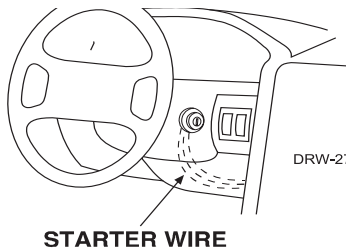

Accessory wire

An accessory wire shows +12V when the key is in the accessory and run positions. It does not show +12V during the cranking cycle. There are often more than one accessory wire in the ignition harness. The correct accessory wire powers the vehicle's climate control system. Some vehicles may have separate wires for the blower motor and the air conditioning compressor. In such cases, it is necessary to add relay to power the second accessory wire.

Tachometer wire

Note: The system has Virtual Tach which automatically test the engine voltage in automatic transmission vehicles. The below wire test would be used only if Virtual Tach or Voltage Mode is not working. When installing this unit on a manual transmission vehicle, the wire **must** be used.

To test for a tachometer wire, a multi meter capable of testing AC voltage must be used. The tachometer wire will show between 1V and 6V AC. In multi-coil ignition systems, the system can learn individual coil wires. Individual coil wires in a multi-coil ignition system will register lower amounts of AC voltage. Also, if necessary, the system can use a fuel injector control wire for engine speed sensing. Common locations for a tachometer wire are the ignition coil itself, the back of the gauges, engine computers, and automatic transmission computers.

WARNING! Do not test tachometer wires using a test light or logic probe (computer safe test light). This will damage the vehicle.

How to find a tachometer wire with your multi meter:

1. Set to ACV or AC voltage (12V or 20V is fine).
2. Attach the (-) probe of the meter to chassis ground.
3. Start and run the vehicle.
4. Probe the wire you suspect of being the tachometer wire with the red probe of the meter.

The wire should read between 1v and 6v and will normally change when revving up the engine. If the voltage changes with engine speed, you have the correct wire.

Wait-to-start bulb wire for diesels

Note: The system has a programmable onboard timer (See Menu#3 Feature 9), so it is not necessary to connect the wait-to-start wire.

In diesel vehicles you can interface with the wire that turns on the WAIT-TO-START light in the dashboard. This wire illuminates the bulb until the vehicle's glow plugs are properly heated. When the light goes out the vehicle can be started. This wire is always available at the connector leading to the bulb in the dashboard. It can also be found at the Engine Control Module (ECM) in many vehicles.

To test for polarity of the wait-to-start wire:

1. Set your multi meter to DCV or DC voltage (12 or 20V is fine).
2. Attach the (+) probe of the meter to (+)12V.
3. Probe the wire that you suspect leads to the bulb with the (-) probe of the meter.
4. Turn the ignition switch to the ON position.
5. If the meter indicates 12 volts until the light goes out, you have isolated the correct wire. The wire's polarity is negative (ground while the bulb is on).

If the meter reads zero volts until the light goes out and then reads 12 volts, you have isolated the correct wire and the wire's polarity is positive.

Parking light wire

The parking light (+) or (-) wire is often found near the switch. Many cars have the switch built into the turn signal lever, with the parking light wire found in the steering column. The same wire is often available in the kick panel or running board.

Some newer vehicles have multiplexed circuits that will also need to be interfaced with (check the vehicle information sheet) these cars usually require that the switch be isolated (5 wired), this unit has a white/brown wire on the main harness to interface with these circuits without having to add an additional relay.

Note: Remember, you need a parking light wire that does not vary with the dimmer setting.

How to find a (+) or (-) parking light wire with your multi meter:

1. Set to DCV or DC voltage (12V or 20V is fine).
2. If you are looking for a positive circuit attach the (-) probe of the meter to chassis ground. If you are looking for a negative circuit, attach (+) probe of your meter to +12V constant.
3. Probe the wire you suspect of being the parking light wire. Usually, the area near the headlight/parking light switch is an excellent area to start, as is the kick panel.
4. Turn on the parking lights. If your meter shows (+)12V, turn off the parking lights and make sure it goes back to zero.
5. If the meter returns to zero, turn the parking lights back on and using the dash light dimmer control, turn the brightness of the dash lights up and down.

If the meter changes more than a volt when using the dimmer, look for another wire. If it stays relatively close to (+)12V, you have found your parking light wire.

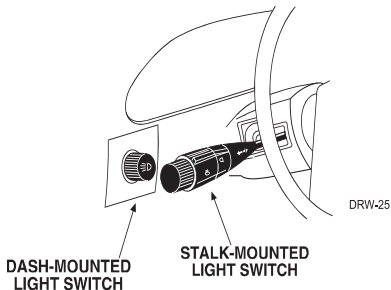

Door pin switch circuit

The best places to test for the door switch wire are:

■ Pin switch

When testing at the pin switch, check the wire to ensure that it “sees” all the doors. Often, the passenger switch will cover all the doors even if the driver’s switch will not.

■ Dome light

This may not be your best choice if the vehicle has delayed dome light supervision, but it will work in any vehicle with completely diode-isolated or normally-closed pin switches.

Once you have determined the wire color, the easiest place to connect to the wire is likely the kick panel, at the windshield pillar - or in the running board. When an easy location is not available, running a wire to the dome light is the best alternative.

How to find a door pin switch trigger wire with your multi meter:

1. Set to DCV or DC voltage (12V or 20V is fine).
2. If you are looking for a positive circuit fasten the (-) probe of the meter to chassis ground. If you are looking for a negative circuit, fasten the (+) probe of your meter to (+)12V constant.
3. Probe the wire you suspect of being the door trigger wire. If the meter reads (+)12V when any door is opened, you have found a trigger wire.

Note: To ensure the wire “sees” all the doors, open each door and check the meter reading.

Making your wiring connections

Before making your connections, plan how your wires will be routed through the vehicle. For instance, the red 12V constant input and the remote start ignition wires will often be routed together to the ignition switch harness. In order to keep the wiring neat and make it harder to find, you may wish to wrap these wires together in electrical tape or conceal them in tubing similar to what the manufacturer used.

There are two acceptable ways of making a wire connection - solder connections and crimp connectors. When properly performed, either type of connection is reliable and trouble-free. Regardless of whether you solder your connections or you use mechanical-type crimp-on connections, ensure that all connections are mechanically sound and that they are insulated.

Cheap electrical tape, especially when poorly applied, is not a reliable insulator. It often falls off in hot weather. Use good-quality electrical tape or heat shrink.

- Never twist-and-tape the wires together without soldering.
- Never use “fuse taps”, as they can damage fuse box terminals.

If you use tapping connectors such as 3M T-Taps (not to be confused with Scotch-Locks), avoid using them in higher-current applications (constant 12V, ground, etc.) Some tapping connectors are inferior in quality and should be avoided.

Primary harness (H1), 12-pin connector

H1/1	RED/WHITE	(-) 200mA TRUNK RELEASE OUTPUT
H1/2	RED	(+)12v CONSTANT INPUT
H1/3	BROWN	(+) SIREN OUTPUT
H1/4	WHITE/ BROWN	LIGHT FLASH -ISOLATION WIRE - PIN 87a of onboard relay
H1/5	BLACK	(-) CHASSIS GROUND
H1/6	VIOLET	(+) DOOR TRIGGER INPUT
H1/7	BLUE	(-) TRUNK PIN/ INSTANT TRIGGER INPUT
H1/8	GREEN	(-) DOOR TRIGGER INPUT
H1/9	BLACK/WHITE	(-) 200mA DOME LIGHT OUTPUT
H1/10	WHITE/BLUE	(-) REMOTE START/ TURBO TIMER ACTIVATION INPUT
H1/11	WHITE	PARKING LIGHT OUTPUT
H1/12	ORANGE	(-) 500mA GROUND WHEN ARMED OUTPUT

Auxiliary harness (H2), 8-pin connector

H2/1	LIGHT GREEN/ BLACK	(-) 200mA FACTORY ALARM DISARM OUTPUT
H2/2	LIGHT GREEN/ WHITE	(-) 200mA FACTORY ALARM ARM OUTPUT
H2/3	WHITE/VIOLET	(-) 200mA AUX 1 OUTPUT
H2/4	VIOLET/BLACK	(-) 200mA AUX 2 OUTPUT
H2/5	WHITE/BLACK	(-) 200mA AUX 3 OUTPUT
H2/6	LIGHT BLUE	(-) 200mA 2ND UNLOCK OUTPUT
H2/7	GRAY/BLACK	(-) DIESEL WAIT TO START INPUT
H2/8	BROWN/BLACK	(-) 200mA HORN HONK OUTPUT

Door lock harness, 3-pin connector

1	BLUE	(+) LOCK (-) UNLOCK OUTPUT
2	EMPTY	NOT USED
3	GREEN	(-) LOCK (+) UNLOCK OUTPUT

There are three harness connections relative to remote start function, including the heavy gauge and input and output harnesses.

Heavy gauge remote start, (H3) 10-pin connector

1	PINK	(+) IGNITION 1 INPUT/OUTPUT
2	RED/WHITE	(30A) FUSED IGNITION 2 / FLEX RELAY INPUT 87
3	ORANGE	ACCESSORY OUTPUT
4	VIOLET	(+) STARTER OUTPUT (CAR SIDE OF THE STARTER KILL WIRE)
5	GREEN	(+) STARTER INPUT (KEY SIDE OF THE STARTER KILL WIRE)
6	RED	(+) FUSED (30A) IGNITION 1 INPUT
7	PINK/WHITE	(+) IGNITION 2 / FLEX RELAY OUTPUT
8	PINK/BLACK	FLEX RELAY INPUT 87A key side (if required) of FLEX RELAY
9	RED/BLACK	FUSED (30A) ACCESSORY/STARTER INPUT
10	N/C	N/C

Remote start input, 5-pin connector

1	BLACK/WHITE	(-) NEUTRAL SAFETY SWITCH INPUT
2	VIOLET/WHITE	TACHOMETER INPUT WIRE
3	BROWN	(+) BRAKE SHUTDOWN WIRE
4	GRAY	N/O or N/C (-) HOOD PIN SWITCH INPUT, ZONE 6
5	BLUE/WHITE	(-) 200 mA 2ND STATUS/REAR DEFOGGER

Remote start auxiliary output, 5-pin

1	PINK/WHITE	(-) 200mA FLEX RELAY CONTROL OUTPUT
2	ORANGE	(-) 200mA ACCESSORY OUTPUT
3	VIOLET	(-) 200mA STARTER OUTPUT
4	PINK	(-) 200mA IGNITION 1 OUTPUT
5	BLUE	(-) 200mA STATUS OUTPUT

Note: Wires 1 - 4 on the remote auxiliary outputs are wired to the (-) triggers for the onboard remote start relays and are not diode isolated. If wiring these wires directly to the vehicle you must place a 1-amp diode in line to prevent feedback from the vehicle.

Wire connection guides

Primary harness (H1)

H1/1 **RED/WHITE** Aux/Trunk release , 200mA (-) output

When the system receives the code controlling trunk release output for longer than 1.5 seconds, the red/white wire will supply an output as long as the transmission continues. This is typically used to operate a trunk/hatch release or other relay-driven function.

Important! Never use this wire to drive anything but a relay or a low-current input! The transistorized output can only supply 200mA of current. Connecting directly to a solenoid, motor, or other high-current device will cause it to fail.

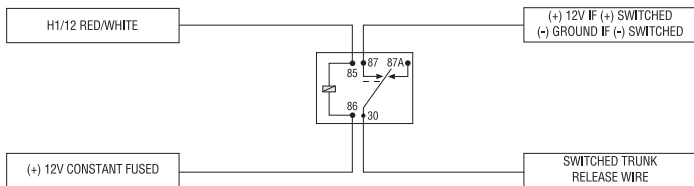

H1/2 **RED** (+)12V Constant power input

Before connecting this wire, remove the supplied fuse. Connect to the battery positive terminal or the constant 12V supply to the ignition switch.

Note: Always use a fuse within 12 inches of the point you obtain (+)12V. Do not use the 15A fuse in the harness for this purpose. This fuse protects the module itself.

H1/3 **BROWN (+)** Siren output

Connect this to the red wire of the siren. Connect the black wire of the siren to (-) chassis ground, preferably at the same point you connected the control module's black ground wire.

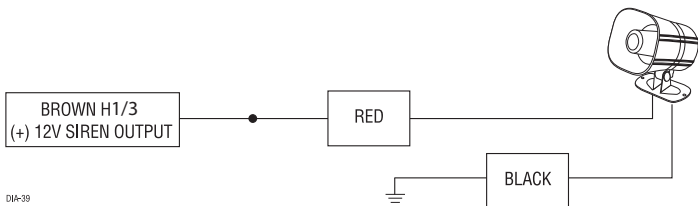

D1A-39

H1/4 **WHITE/BROWN** - Onboard light flash relay

This wire connects to pin 87a of the onboard light flash relay. It is used whenever light switch isolation on the vehicle is necessary. If the vehicle has a multiplex circuit that needs the light switch isolated, you can remove the onboard light flash fuse and replace it with the specified resistor (paying attention to the polarity selection).

Multiplex Lightflash Interface

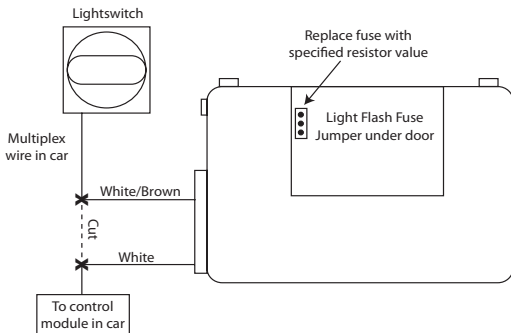

We recommend that you do not use a factory ground. Ground all your components including the siren, to the same point in the vehicle, (preferably the kick panel). Scrape away any paint and use a factory bolt or make your own ground with a self-tapping screw and a star washer.

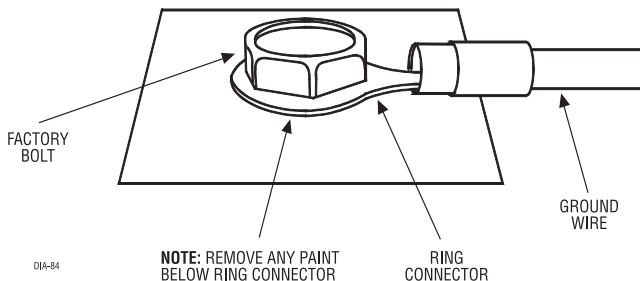

H1/6 VIOLET (+) Door trigger input, zone 3

This wire is used in vehicles that have a positive (+) switched dome light circuit. Connect the violet wire to a wire that shows (+)12V when any door is opened, and ground when the door is closed. This wire will report Zone 3.

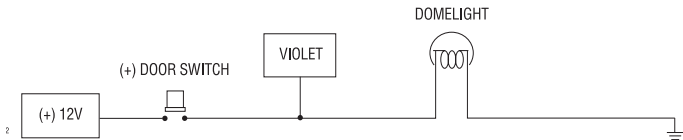

H1/7 BLUE (-) Trunk pin /instant trigger input, zone 1

This input will respond to a negative input with an instant trigger. This is ideal for a trunk pin. It can also be used with Directed single-stage sensors and will report on Zone 1.

H1/8 GREEN (-) Door trigger input, zone 3

Most vehicles use negative door trigger circuits. Connect the green wire to a wire which shows ground when any door is opened. In vehicles with factory delays on the dome light circuit, there is usually a wire that is unaffected by the delay circuitry. This wire will report Zone 3.

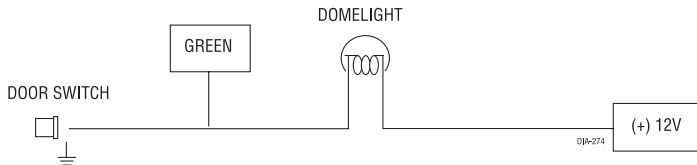

H1/9 **BLACK/WHITE** (-) 200 mA dome light supervision output

Connect this wire to the optional dome light supervision relay as shown below:
Important! This output is only intended to drive a relay. It cannot be connected directly to the dome light circuit, as the output cannot support the current draw of one or more light bulbs.

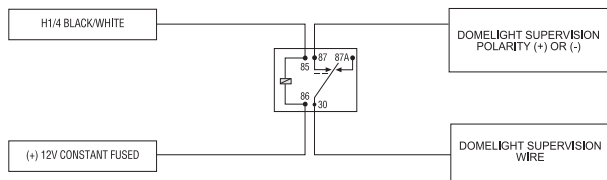

H1/10 **WHITE/BLUE** Remote start turbo timer (-) activation input

This input comes from the factory set to 1 activation pulse. This means that it is necessary to have a single ground pulse on the white/blue wire for the remote start to activate or to deactivate. This wire can also be used to activate the Turbo Timer mode when the car is running and this wire receives a ground.

Note: The number of activation inputs can be programmed to 1 or 2 pulses with an optional momentary switch. This setting affects both the input wire and the remote control when operating the remote starter.

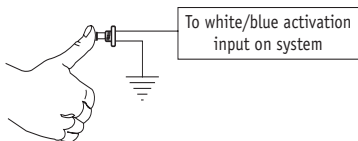

H1/11 **WHITE** Parking light output

This wire should be connected to the parking light wire in the vehicle. See Setting the light flash polarity section of this guide for polarity settings.

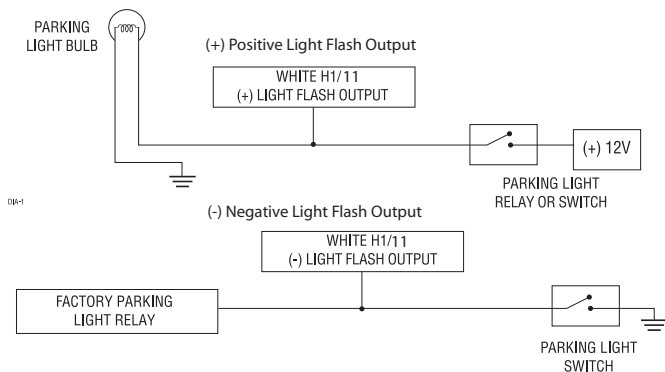

Note: For parking light circuits that draw 10 amps or more, the internal jumper must be switched to a (-) light flash output. (See Setting the light flash polarity section of this guide.) P/N 8617 or a standard automotive SPDT relay must be used on the H1/2 light flash output harness wire.

H1/12 **ORANGE** (-) ground-when-armed output

This wire supplies a (-)500 mA ground as long as the system is armed. This output ceases as soon as the system is disarmed. The GWA can be hooked up to a window control module, a voice module or any accessory that requires a ground when armed.

Auxiliary harness (H2)

H2/1 LIGHT GREEN/BLACK (-) Factory alarm Disarm

This wire sends a negative pulse every time the remote start is activated, channel 2 is activated (programmable on/off) or when the doors are unlocked with the remote. This can be used to pulse the disarm wire of the vehicle's factory anti-theft device. Use a relay to send a (-) or (+) pulse to the disarm wire as shown in the following diagrams.

Relay for Negative (-) Disarm Wire Relay for Positive (+) Disarm Wire

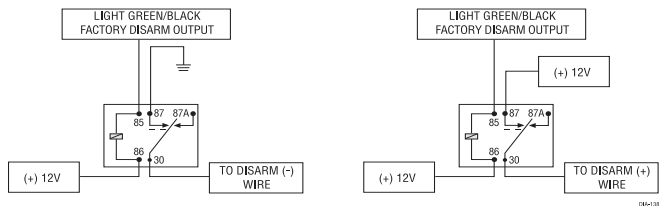

H2/2 GREEN/WHITE (-) Factory alarm Arm

This wire sends a negative pulse every time the remote start shuts down or when the doors are locked with the remote. This can be used to pulse the arm wire of the vehicle's factory anti-theft device. Use a relay to send a (-) or (+) pulse to the arm wire.

H2/3 WHITE/VIOLET 200 mA (-) programmable Aux 1 output

This wire provides 200 mA programmable output whenever the transmitter buttons controlling Aux 1 channel is pressed. (See descriptions for Aux 3)

Warning! Never use this wire to drive anything but a relay or a low-current input! This transistorized output can only supply 200 mA. Connecting directly to a solenoid, motor, or other high-current device will cause the module to fail.

H2/4 **VIOLET/BLACK** 200 mA (-) programmable Aux 2 output

This wire provides 200 mA programmable output whenever the transmitter buttons controlling Aux 2 channel is pressed. (See descriptions for Aux 3.)

Warning! Never use this wire to drive anything but a relay or a low-current input! This transistorized output can only supply 200 mA. Connecting directly to a solenoid, motor, or other high-current device will cause the module to fail.

H2/5 **WHITE/BLACK** 200 mA (-) programmable Aux 3 output

This wire provides 200 mA programmable output whenever the transmitter button (s) controlling Aux 3 is pressed. This output can be programmed to provide the following types of outputs

- **Validity:** Output that sends a signal as long as the transmission is received.
- **Latched:** Output that sends a signal when the Aux channel button is pressed and continues until the same button is pressed.
- **Latched, reset with ignition:** Similar to the latched output, this type of output turns On the first time the Aux channel button is pressed, and turns Off the next time the same button is pressed. This type of output additionally stops and resets whenever the ignition is turned On and then Off.
- **30 seconds timed:** The output sends a continuous signal for 30 seconds.

Note: Bitwriter® programs from 1 to 90 seconds.

Warning! Never use this wire to drive anything but a relay or a low-current input! This transistorized output can only supply 200 mA. Connecting directly to a solenoid, motor, or other high-current device will cause the module to fail.

H2/6 LIGHT BLUE (-) 200mA 2nd unlock output

This wire produces a (-) 200mA output for progressive locks in which the driver door unlocks first and the remaining locks will unlock with a second press of the unlock button on the remote.

Note: This feature will need to be programmed “On” to function correctly (see System Feature Menu #1, feature 8)

H2/7 GRAY/BLACK (-) Diesel wait-to-start input

Connect this wire to the wire in the vehicle that sends the signal to turn on the WAIT-TO-START bulb in the dashboard. In most diesels the wire is negative (ground turns on the bulb) and the GRAY/BLACK wire can be directly connected to the wire in the vehicle. If the vehicle uses a positive wire (12V to turn on the bulb) a relay must be used to change the polarity.

Note: The system has a programmable onboard timer (See Feature menu#3, feature 9) so it is not mandatory to connect to the wait-to-start wire in the vehicle.

Note: A 1-amp diode must be installed in line on the factory wire between the wait-to-start indicator and the ECM. (See the following diagram for details.)

(-) WAIT TO START WIRE

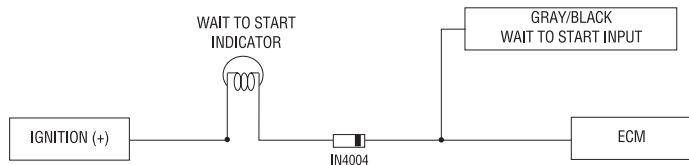

DIA-257

(+)WAIT-TO-START WIRE

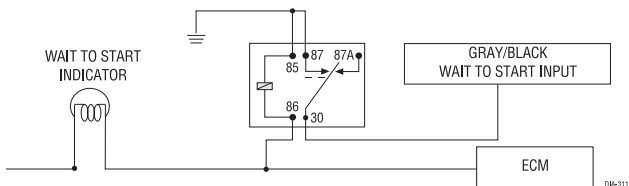

H2/8 BROWN/BLACK (-) Horn honk output

This wire is a low current output (200mA) and can be hooked to the horn honk wire in the vehicle. It can be programmed to sound only during full trigger or to be used like a siren output with arm/disarm chirps. Refer to *System Features Menu#1, Feature 10* for more information.

Door lock wire diagrams

Important! Depending on the vehicle, the door locks may be controlled by an optional data bus expansion module. If so, no door lock interface wiring is required.

There are eight different types of door lock systems (Type A - H). Refer to the vehicle-specific wiring instructions on the web and the chart below to help determine which door lock system your vehicle uses.

Note: The more common type of door lock systems are Type A or Type B. Any other, Types C thru H, will require external relays or a Directed Electronics 451M.

Type A: Three-wire (+) pulse controlling factory lock relays.

Type B: Three-wire (-) pulse controlling factory lock relays.

Type C: Direct-wired reversing-polarity switches. The switches are wired directly to the motors. This type of system has no factory relays.

Type D: Adding one or more aftermarket actuators. These include central locking systems without an actuator in the driver's door, but with factory actuators in all the other doors.

Type E: Electrically-activated vacuum systems.

Type F: One-wire system - cut to lock, ground to unlock.

This is a very rare system found mainly in early 90's imports and some newer Hyundais.

Type G: Positive (+) multiplex. One wire controls lock and unlock using resistor(s).

Type H: Negative (-) multiplex. Same as Type G system, but uses (-) pulse instead.

Note: You can use a 456L door lock learn module for Type G and H, instead of relays and resistors.

Type A: Three-wire (+) pulse controlling factory lock relays

The system can control Type A door locks directly, with no additional parts. The switch will have three wires on it; one will test (+)12 volt constantly. The others will alternately pulse (+)12 volt when the switch is pressed to the lock or unlock position.

If you cannot get to the switch, and you find a set of wires that pulse (+)12 volt alternately on lock and unlock, make sure that it is not a Type C direct-wire system.

Here is a test: Cut the wire that pulses (+)12V on lock, and then operate the switch. If the lock stops working, then you have the correct wire.

Important: Remember that these wires' functions reverse between Type A and type B.

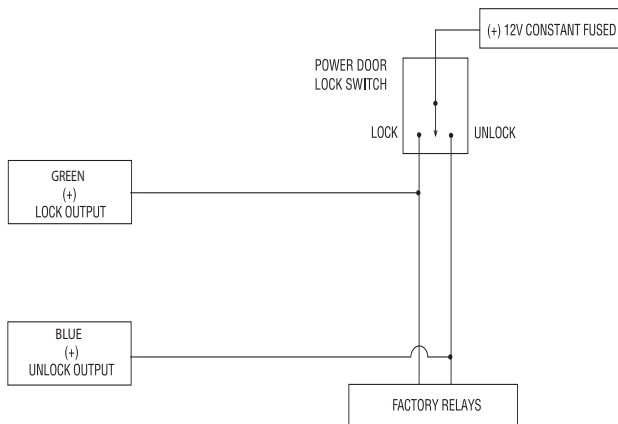

Type B: Three-wire (-) pulse controlling factory lock relays

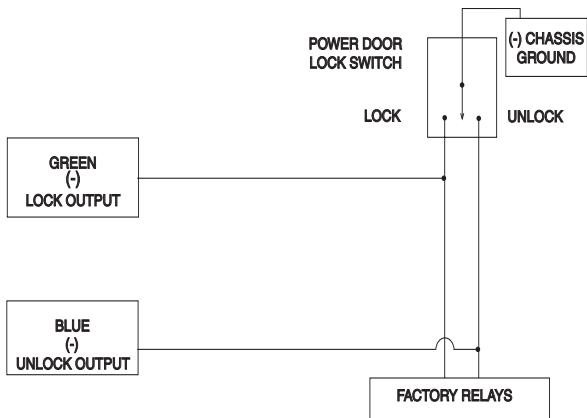

This system works similar to the Type A system, but uses a negative to control the relays in the vehicle.

Note: If your locks operate in the reverse, (lock when pressing unlock, and unlock when pressing lock) then switch the lock/unlock wires and the locks will operate correctly.

Type C: Direct-wired reversing polarity switches

Interfacing with a reversing polarity system requires either two relays OR one DEI 451M (not included).

It is critical to identify the proper wires and locate the master switch to interface the door locks properly. This door lock system will be referenced on our vehicle specific wiring information sheet as a system.

Locate wires that show voltage on lock and unlock. Cut one of the suspected wires and check operation of the locks from both switches. If one switch loses operation in both directions and the other switch operates in one direction only the system is Type C; you have located one of the target wires. The switch that lost all operation is the master switch.

If one switch works in both directions and the other switch works in only one direction, you have a Type A system. If both switches still operate, but one or more doors has stopped responding entirely, you have cut a motor lead. Reconnect it and continue to test for another wire. Once both wires have been located and the master switch has been identified, cut both wires and interface as shown in the following diagram.

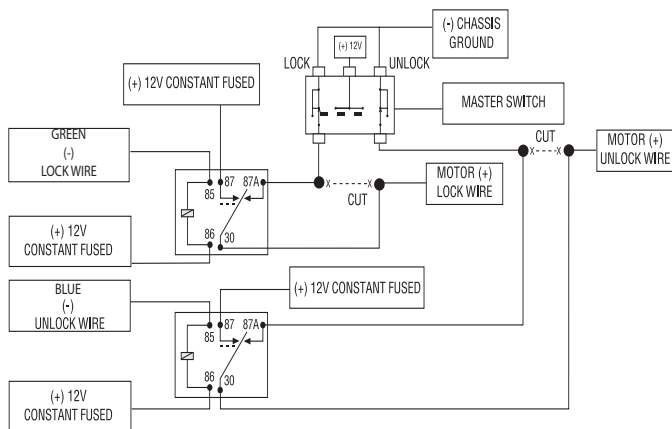

Caution: If these wires are not connected properly, you will send (+) 12 volts directly to (-) ground, possibly damaging the alarm or the factory switch.

Type D: Adding one or more aftermarket actuators

In order for this system to control one or more aftermarket actuators, a DEI 451M (not included) or two relays are required. Vehicles without factory power door locks require the installation of one actuator per door. This requires mounting the door lock actuator inside the door.

Other vehicles may only require one actuator installed in the driver's door, if all door locks are operated when the driver's lock is used. The fuse used on 12 volt inputs should be 7.5A per motor installed in the vehicle.

Important: Do not connect the outputs of the alarm directly to the actuator.

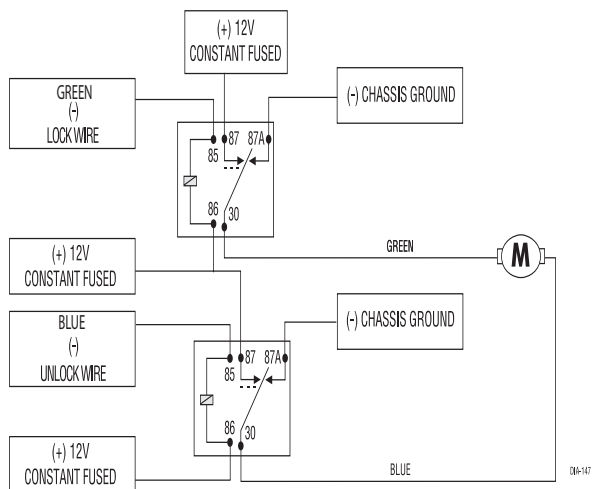

Note: Directed Electronics offers an adaptor (P/N 524T) for cars that have cable driven doors.

Type E: Electrically-activated vacuum systems

Type E door locks are controlled by an electrically activated vacuum pump. Some Mercedes and Audis use the Type E system. The control wire can be found in either kick panel and will show (+)12 volts when doors are unlocked and (-) ground when doors are locked and when turning the key in the driver or passenger door.

To interface, see diagram below. The system must be programmed for 3.5 second door lock pulses.

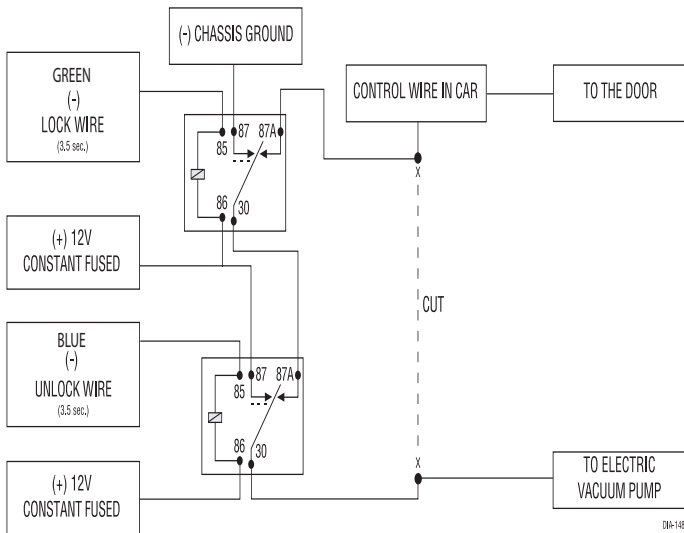

Type F: One-wire system - cut to lock, ground to unlock

Type F door locks usually require a negative pulse to unlock and cutting the wire to lock the door. In some vehicles, these functions are reversed. One relay (not included) is used to interface to this type of system.

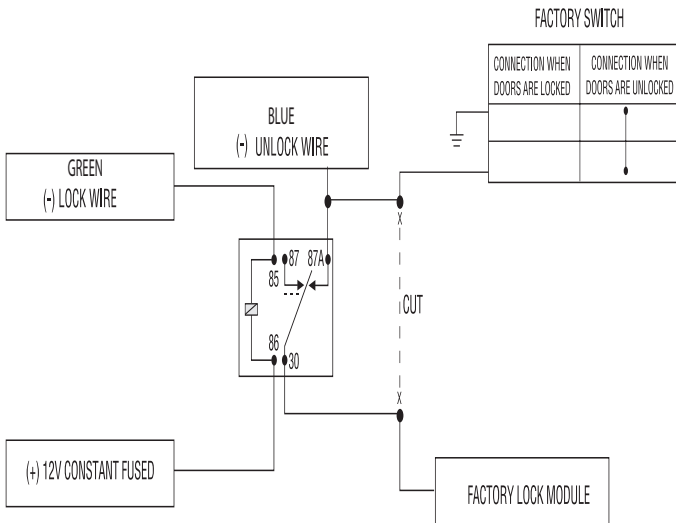

Type G: Positive (+) multiplex

The door lock switch or door key cylinder may contain either one or two resistors that will trigger the lock control module through a positive resisted pulse. When interfacing with this type of door lock system, two relays or a DEI 451M must be used.

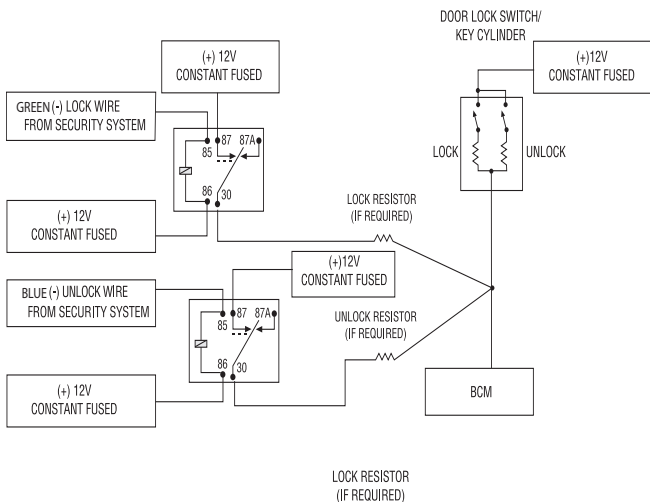

Single-Resistor Type

If one resistor is used in the door lock switch/key cylinder, the wire will pulse (+)12 volt in one direction and less than (+)12 volt when operated in the opposite direction.

Two-Resistor Type

If two resistors are used in the factory door lock switch/key cylinder, the switch/key cylinder will read less than (+)12 volt in both directions.

Type H: Negative (-) multiplex

The door lock switch or door key cylinder may contain either one or two resistors. When interfacing with this type of door lock system, two relays or a DEI 451M must be used.

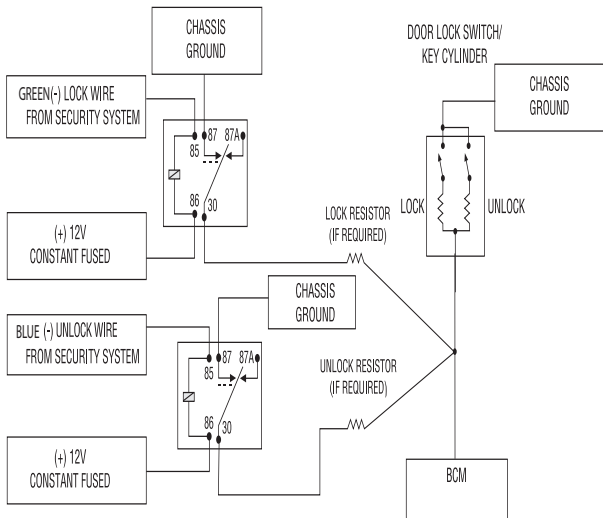

Single-Resistor Type

If one resistor is used in the door lock switch/key cylinder, the wire will pulse ground in one direction and resistance to ground when operated in the opposite direction.

Two-Resistor Type

If two resistors are used in the factory door lock switch/key cylinder, the door lock switch/key cylinder will read resistance to ground in both directions.

To determine the resistor values, refer to the steps on page 43.

Determining the Proper Resistor Values

To determine the resistor values, the door lock switch/key cylinder must be isolated from the factory door lock system. For all testing, use a calibrated digital multi meter that is set to ohms.

1. Cut the output wire from the door switch/key cylinder in half.
2. Test with one meter probe on the switch side of the cut wire, if testing for a positive circuit place the other probe to a constant (+)12V source. Good constant (+) 12V references include the power input source to the door lock switch/key cylinder, the ignition switch power wire, or the battery (+) terminal.

When testing for a negative, place one meter probe on the switch side of the cut wire and the other probe to a good chassis ground. Good references would include the ground input source to the door locks switch/key cylinder or on bare metal in the kick panel or the battery (-) terminal.

3. Operate the door lock switch/key cylinder in both directions to determine the resistor values. If the multi meter displays zero resistance in one direction, no resistor is needed for that direction.
4. Once the resistor value(s) is determined, refer to the Type G or H wiring diagram for proper wiring.

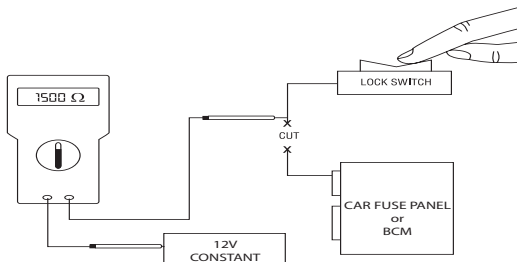

Heavy Gauge, 10-pin connector

There are 9 heavy gauge wires coming from the large 10-pin connector. They are used to energize the ignition circuits in the vehicle. It is crucial that these connections are well made and capable of handling the current demands. For this reason, Scotch-Locks, T-taps and other such connectors are strongly discouraged.

H3/1 PINK – (+) Ignition 1 input/ output

Connect this wire to the ignition wire in the vehicle. This wire not only supplies voltage for the ignition line in the vehicle, it is also the ignition feed for the security system.

H3/2 RED/WHITE – (+) 30a fused ignition 2/flex relay, pin 87, input.

This wire is the polarity feed for the ignition 2/flex relay.

H3/3 ORANGE – Accessory output.

Connect this wire to the accessory wire that powers the climate control system

H3/4 VIOLET – Starter output.

This wire hooks up to the starter side of the starter wire in the car. This wire is also pin 30 of the onboard starter kill relay.

H3/5 GREEN – Starter input.

After cutting the starter wire connect the GREEN wire to the end going to the ignition switch. This wire is pin 87a of the onboard starter kill relay.

H3/6 RED – 30 amp fused Ignition 1 relay input.

This wire is the polarity feed for the Ignition 1 relay.

H3/7 PINK/WHITE – Ignition 2 flex relay output.

This wire is factory programmed as Ignition 2 and can be programmed as a 2nd accessory or 2nd starter.

H3/8 PINK/BLACK – 87a of Ignition 2/Flex relay.

This wire is used when an ignition switch isolation on the vehicle is necessary. This is common on Toyota and Nissans which required the use of Tech Tip document #1077. (See menu # 3 Feature 8 for programming options)

H3/9 RED/BLACK – 30a fused accessory/starter relay input

This wire is the polarity feed to the accessory and starter relays.

Remote start input - 5-pin connector

BLACK/WHITE Neutral safety switch input

Connect this wire to a ground source if installing this unit in an automatic transmission vehicle. If this unit is being installed in a manual transmission vehicle then connect it to the emergency brake wire. This input **MUST** rest at ground in order for the remote start system to operate.

Important! Always perform the steps outlined in Safety Check section to verify that the vehicle cannot be started in **ANY** drive gear and that the override switch is functioning properly.

VIOLET/WHITE Tachometer input

This input provides the module with information about the engine's revolutions per minute (RPMs). It can be connected to the negative side of the coil in vehicles with conventional coils. In multi-coil and high energy ignition systems locating a proper signal may be more difficult. (See Finding the Wires You Need section of this guide.) Once connected, you must teach the system the tach signal.

Note: This wire **MUST** be used when installing this unit on a manual transmission.

BROWN (+) Brake shutdown input

This wire **MUST** be connected to the vehicle's brake light wire. This is the wire that shows (+) 12V when the brake pedal is depressed. The remote start will be disabled or shut down any time the brake pedal is depressed. **Note:** This wire **MUST** be used when installing this unit on a manual transmission.

GRAY (N/O or N/C) Hood pin shutdown input

This wire **MUST** be connected to a hoodpin switch. This input will disable or shut down the remote start when the hood is opened. It will also trigger the security system if the hood is opened while the system is armed and report Zone 6. (See Feature Descriptions, Menu #1 feature 11 for details about programming.)

BLUE/WHITE (-) 200mA 2nd Status/defroster output

This wire supplies a 200mA output as soon as the module begins the remote start process. The H3/1 BLUE wire can also be used to activate the defogger trigger (latched/pulsed) 10-seconds after the remote start engages. (See the Feature Descriptions, Menu#3, feature 11 for details about programming this output.)

Outputs for optional ext. remote start relays

These signals are provided to drive additional optional relays.

PINK/WHITE (-) 200mA Flex Relay Control Output

This wire is programmed as (-) 2nd ignition output from factory and can be programmed (to drive a relay) as a (-) starter or accessory output.

ORANGE (-) 200mA Accessory output

This wire works like the main accessory wire and can be used (with a relay) to drive any additional accessory circuits in the vehicle.

VIOLET (-) 200mA Starter output

This wire works like the starter wire and can be used (with a relay) to drive any additional starter circuits in the vehicle.

PINK (-) 200mA ignition 1 output

This wire works like the ignition 1 wire and can be used (with a relay) to drive any additional ignition circuits in the vehicle.

Note: Wires 1 - 4 on the remote start auxiliary outputs are wired to the (-) triggers for the onboard remote start relays and are not diode isolated. If wiring these wires directly to the vehicle you must place a 1-amp diode in line to prevent feedback from the vehicle.

BLUE (-) 200mA status output

This wire supplies an output as soon as the module begins the remote start process. It can be used to activate a bypass module or power the key sense wire in most vehicles to disarm the factory alarm without unlocking.

Note: Check vehicle information to verify if a bypass module is needed or if the key sense wire is needed.

Neutral safety switch interface

Some vehicles do not have an electrical neutral safety switch. Instead, the vehicle has a mechanical neutral safety switch that physically interrupts the starter wire and is used when the vehicle is in any drive gear. If the remote start is interfaced before this switch, it will provide protection from starting in gear. However, some vehicles combine the column shift mechanism and the mechanical neutral safety switch into one mechanical part.

In these vehicles, you cannot interface the remote start system before the neutral safety switch; it needs to be interfaced differently. With this type of vehicle, if the car is left in a drive gear and the remote start system is activated, the vehicle will move and may cause damage to persons or property.

According to available information, the only vehicles currently manufactured this way are most General Motors trucks, sport utility vehicles and column shifting passenger cars. Available information also indicates that pre-1996 Dodge Dakota pickups with 2.5 liter motors are manufactured this way as well.

GM vehicles that have the neutral safety switch built into the column shifter can usually be identified by a purple starter wire. Typically, vehicles that use an outboard mechanical switch use a yellow wire from the ignition switch to the mechanical switch and a purple wire from the mechanical switch to the starter itself. Remember, this is only a rule of thumb and is not intended as a substitute for proper testing.

We suggest the following procedure to test for vehicles manufactured in this way.

Note: You must complete the remote start system installation before doing the following test. Ensure that the remote start system is functioning normally. This includes connecting to the brake as a shut-down.

Testing the neutral safety switch

1. Make sure there is adequate clearance to the front and rear of the vehicle because it may move slightly.
2. Make sure the hood is closed and there are no remote start shut-downs active.
3. Set the emergency brake.
4. Turn the key to the "run" position, this will release the shifter.
5. Place the car in drive (D).
6. Place your foot directly over the brake pedal, but do not depress it. Be ready to step on the brake if the starter engages.
7. Activate the remote start system.
8. If the starter engages, immediately depress the brake to shut the remote start system down. If the starter does not engage, no additional safety system is required.

If the starter engages and the vehicle is a General Motors product or Dodge Dakota pickup, refer to the following text and diagrams for an alternative shut-down method which will prevent the starter from engaging. If the vehicle is not a General Motors product or a Dodge Dakota pickup, please call Directed Electronics Technical Support for an alternative shut-down method. Do not return the vehicle to the customer until this feature is properly installed!

Every vehicle built in this fashion requires that the shifter be placed in park to remove the keys from the ignition. As a result, it is possible to use the key-in-ignition sense switch to prevent remote starting if the keys are in the ignition. The following diagrams illustrate how to accomplish this. The first diagram applies to all General Motors vehicles that have failed the above test.

The second diagram applies to all pre-1996 Dodge Dakota pickup trucks with 2.5 liter motors. This solution has one side effect - if the customer inserts the key in the ignition with the driver's door open, the remote start system will shut down. If this interface is used it is important to inform the customer to close the driver's door before inserting the key into the ignition when the remote start is active. This will allow the customer to turn the key on and shut the remote start down by pressing the brake without the key sense wire shutting down the unit prematurely.

However, due to future manufacturer changes in vehicles, it is possible that this may not apply to all vehicles. In addition, color variations are possible from model to model; make sure to test the circuit carefully. Please call Directed Electronics Technical Support if you need assistance in making this interface.

Important! Once the interface is complete, attempt to remote start the vehicle with the door closed and the key in the ignition. The vehicle should not start. If it does, recheck the connections.

General Motors trucks, sport utility vehicles and column shifting passenger vehicles:

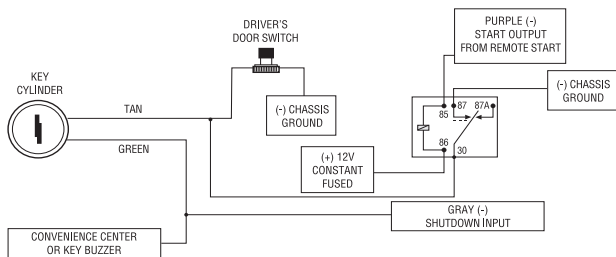

18-17

Pre-1996 Dodge Dakota pickups with 2.5 liter motors:

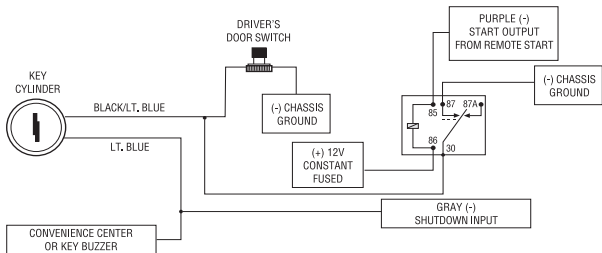

18-18

Plug-in LED and valet/program switch

The LED and valet switch are incorporated into the control center the LED line will plug into the white 2-pin port and the Valet switch line will plug into the blue 2-pin port.

Note: Onboard LED and valet switch can be substituted with an optional outboard LED (P/N 8634 for Blue LED and 8633 for red LED) and an outboard valet switch (P/N 8631).

Programmer interface - 3-pin black plug

The black 3-pin port is provided for programming the unit using the Bitwriter (p/n 998T). When using the Bitwriter, it is possible to configure any and all of the programmable functions as well as lock the Remote Control and System Features Learn Routines so that unauthorized users cannot change the configuration or program remote controls to the unit.



When the learn routines have previously been programmed using the Bitwriter, they may have been locked. Before proceeding with reprogramming the learn routines, they must be unlocked with the Bitwriter - this cannot be done manually with the Valet switch.

Note: Bitwriters require software v2.5. Bitwriters with date code of 6C or older require an IC upgrade (p/n 998M). Bitwriter 2 compatible.

Optional sensor port - 4-pin connector

Note: There is a shock sensor built onboard the main unit.

This connector is an optional sensor port to add sensors to the security system. Optional sensors that may be used are: 508D Doubleguard Proximity Field Disturbance, 509U Ultrasonic Sensor, 506T Glass Break Sensor, and 507M Digital Tilt Sensor.

This input can also be used for a second 504D Doubleguard Shock Sensor, or for additional pin and magnetic switches.

Alarm trigger inputs shorter than 0.8 seconds will trigger the WarnAway response, while inputs longer than 0.8 seconds will trigger the Full Alarm sequence.

Note: You will need to add a 4-pin plug to interface with any hardwired switches.

Tach learning

To learn the tach signal:



1. Start the vehicle with the key.

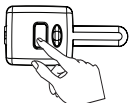

2. Within 5 seconds, press and hold the Valet/Program switch.



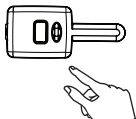

3. After 3 seconds the LED will light constant when the tach signal is learned.



4. Release the Valet/Program switch.

Tach threshold On/Off

In most cases, this jumper can be left in the OFF position. Some new vehicles use less than 12 volts in their ignition systems. The unit may have trouble learning the tach signal in these vehicles. Changing the jumper to the ON setting changes the trigger threshold of the digital tach circuit so it will work properly with these vehicles.

TACH THRESHOLD OFF (DEFAULT) 
TACH THRESHOLD ON 



D2D Jumper settings

The security system has the ability to work with a compatible module through the D2D lines. There are two settings: one for using an internal docking module, (p/n 400N) or an external docking module. The factory setting is for the internal docking module. When using an external module the jumper settings must be changed.

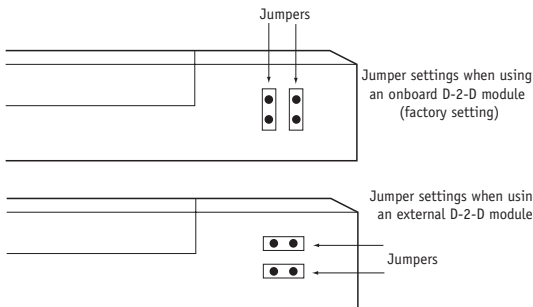

Setting the light flash polarity

Light flash (+) / (-) polarity

The internal fuse is used to determine the light flash output. In the (+) position, the onboard relay will output (+)12V on the WHITE wire, H1/11. In the (-) position, the on-board relay will supply a (-) output. When wiring into a multiplex circuit, you can replace the fuse with a resistor (paying attention to the polarity setting). (Refer to diagram on p.25, H1/4 White/ Brown wire description).

Note: For parking light circuits that draw 10 amps or more, the internal jumper must be switched to a (-) light flash output. P/N 8617 or a standard automotive SPDT relay must be used on the H1/11 light flash output harness wire.

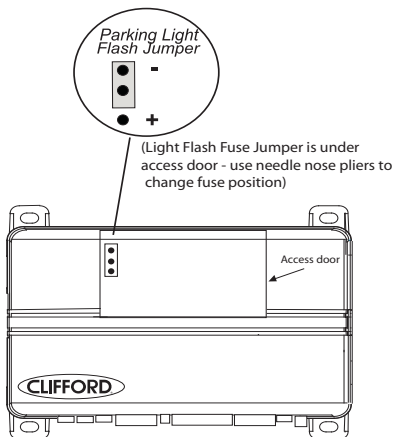

Remote control learn routine™

The remote uses a Supercode Protocol so the remote will need to be setup before programming the system. To enter the remote setup mode you will need to hold the “function” button on the remote until the remote gives a long beep and the transmit LED comes on solid (approximately 8 seconds). Then press and hold the “remote start” button until the remote beeps three times and the amber Transmit LED lights up. Next enter the remote control learn routine and choose the function for “auto learn configuration” listed on the program grid.

Note: You do not need to go through the setup for the other features in the menu.

The system comes with one 1-way and one 2-way remote control that are already programmed to the system. The system can store up to 4 different remote control codes in memory. After entering the setup mode on the remotes, use the following learn routine to add remote controls to the system.

The learn routine may be locked if previously programmed using the Bitwriter®. If the siren generates one long chirp when attempting to program the unit, the learn routine is locked and must be unlocked using the Bitwriter® before proceeding.

The Valet/Program switch, plugged into the blue port, is used for programming. There is a basic sequence to remember whenever programming this unit: Door, Key, Choose, Transmit and Release.



1. Open a door. (The GREEN wire, H1/8, or the VIOLET, H1/6 must be connected.)



2. Insert the key. Turn the ignition to the ON position. The heavy gauge pink wire must be connected.

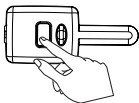

3. Choose. Within 10 seconds, press and release the Program switch corresponding to the number of the desired function step listed in the following table.

Once you have selected the function step, press the switch once more and **hold** it. The LED will flash and the siren will chirp to confirm the selected functional step. Do not release the Program switch.

Step	Function
1	Auto Learn Standard Configuration* (default) The auto learn configuration will automatically setup the remotes button configuration. Note: Due to the Supercode protocol, you cannot change the configuration.
2	Delete remotes: This feature will erase all remotes from the memory of the security system. This is useful in cases when a customer's remote is lost or stolen. Note: This will not reset the programmed features of the security system or reset the Virtual Tach setting.
3	Reset Features: This resets features all of the security system to the factory default settings. Note: This feature does not delete the remotes from the security system or reset the Virtual Tach setting.
4	Virtual Tach Reset: Deletes all previously learned values for Virtual Tach, and on the next remote start sequence the unit will begin virtual tach initialization. Note: The "Zap" feature on the Bitwriter will not reset the Virtual tach setting.



4. Transmit. While holding the Valet/Program switch, press the  button on the remote control. The unit will chirp to confirm that the code has been successfully programmed. It is not possible to teach a remote control button to the system more than once.

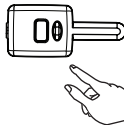

5. Release. Once the code is learned, the Valet/Program switch can be released.

You can advance from one function step to another by releasing the Valet/Program switch and tapping it to advance function steps and then **HOLDING** it.

Learn Routine is exited if:

- The door is closed
- The ignition is turned off
- The program switch is pressed too many times
- More than 30 seconds elapses between steps



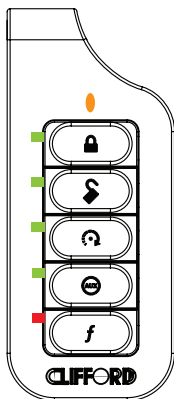

Remote control configuration

Responder LE 2-way



Note: The one-way remote only has the transmit LED and will not give any confirmation tones.

The remote control buttons that operate the features of the security and remote start system are described below. The buttons will operate in this configuration when the remote control is programmed using the Step 1 Auto-learn routine.

Level Button	f x 0	f x 1	f x 2	f x 3	f x 4
 LOCK	ARM	SILENT ARM	SENSOR BYPASS	ARMED (SILENT SENSOR)	ARMED (SILENT TRIGGER)
 UNLOCK	DISARM	SILENT DISARM	VALET MODE	CAR FINDER	—
 REMOTE START	REMOTE START	RUNTIME RESET	TIMER MODE	SMART START	REAR DEFOGGER
 AUX	TRUNK RELEASE	AUX 1	AUX 2	AUX 3	—
 FUNCTION	FUNCTION SHIFT	CABIN TEMPERATURE REQUEST (2-way Only)	ARM STATUS (2-way Only)	RUNTIME CHECK (2-way Only)	LAST TRIGGER REQUEST (2-way Only)

Note: To access “Cabin temperature request, Arm status, Runtime check and Last trigger request, press the “f” button the specified amount of times, and then hold the “f” button.

System features learn routine

The System Features Learn Routine dictates how the unit operates. It is possible to access and change any of the feature settings using the Valet/program switch. However, this process can be simplified by using the Bitwriter®. Any of the settings can be changed and then assigned to one of four remote controls. This feature is called Owner Recognition. Each time that particular remote control is used to disarm the system, the assigned feature settings will be recalled. Owner Recognition is only possible when programming the unit via the Bitwriter®.



If programming with the Bitwriter®, the learn routine can be locked or unlocked. If the learn routine has previously been locked, it must be unlocked with Bitwriter® - this cannot be done manually with the Valet switch.



1. **Open a door.** (The GREEN wire, H1/8, or the VIOLET, H1/6 must be connected.)



2. **Ignition.** Turn the ignition on, then off. (The heavy gauge PINK wire must be connected.)

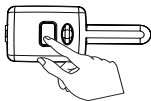

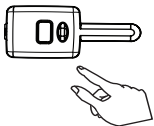

3. **Select a Menu.** Press and **HOLD** the Valet/Program switch. (The Valet/Program switch must be plugged into the blue port.) After three seconds the siren will chirp once indicating entry to the Basic Features Menu. If this is the menu you want, release the button and go on to Step 4. If the button is not released, the program jumps to the next menu and the siren chirps twice. There are three possible menus. Once you have selected the menu you want, release the Valet/Program switch.

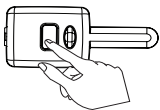

4. Select a Feature. Press and release the Valet/Program switch the number of times corresponding to the feature you wish to change. For example, to access the third feature, press and release 3 times. Then press the button once more and HOLD it. The siren will chirp the number of times equal to the feature you have accessed.



5. Program the Feature. While holding the Valet/Program switch, you can toggle the feature on and off using the remote control. Pressing the button that arms the system will select the one chirp or default setting. Pressing the button that disarms the system will select the two chirp setting.

Note: Some features have more than two possible settings. Pressing  or  will toggle through the two-chirp and higher settings.

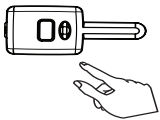

6. Release. Valet/Program switch.

Once a feature is programmed:

- Other features can be programmed within the same menu
- Another menu can be selected
- The learn routine can be exited if programming is complete

To access another feature in the same menu:

1. Press and release the Valet/Program switch the number of times necessary to advance from the feature you just programmed to the next one you want to program.
2. Then press the Valet/Program switch once more and hold it.

For example, if you just programmed the third feature in the menu and you want to program the seventh feature in the menu, press and release the Valet/Program switch four times and then press it once more and hold it. The siren will chirp seven times to confirm access to the seventh feature.

To select another menu:

1. Press and hold the Valet/Program switch.
2. After three seconds, the unit will advance to the next menu and the siren will chirp, indicating which menu has been accessed.

For example, if you just programmed some features in the first menu and you want to program a feature in the third menu, press and hold the Valet/Program switch. After three seconds, the siren chirps twice indicating access to the second menu. Continue to hold the button and three seconds later the siren will chirp three times indicating access to the third menu. Features in the third menu are then programmable following steps 4 through 6 of the System Features Learn Routine procedure.

The learn routine is exited if any of the following occurs:

- The open door is closed
- The ignition is turned On
- There is no activity for 30 seconds
- The Valet/Program switch is pressed too many times

Feature menus

Menu 1 - Security features

The default settings are indicated in **bold** type.

Menu Item	Feature	Opt. 1	Opt. 2	Opt. 3	Opt.4	Opt. 5+
1	System Arming Mode	Active	Passive Arm w/o lock	Passive Arm w/lock	Auto re-arm w/o lock	Auto Re-arm w/Lock
2	Panic Mode	On	Ign Off only	Off		
3	Confirmation Chirps	On w/Warn chirps on	On w/Warn chirps off	Off w/Warn chirps on	Offw/Warn chirps off	
4	Siren duration	30 sec	60 sec			
5	Ign-controlled locks	No Ign-locking	Lock & Unlock	Lock Only	Unlock Only	
6	DoorLock Pulses	Single	Double Unlock Only	Double Lock Only	Double Lock & Unlock	
7	DoorLock Output Duration	0.8sec	3.5 sec	0.4 sec		
8	2nd Unlock	No 2nd unlock	2nd unlock on Ign-control after first unlock	2nd unlock on Ign-control with first unlock		
9	Comfort Closure	No Comfort Closure	Comfort Closure 1	Comfort Closure 2		
10	Horn function	Full Alarm Only	Siren Function 20 mS	Siren Function 30 mS	Siren Function 40 mS	Siren Function 50 mS
11	Hood Trigger Type	Normally Open	Normally closed			
12	Sensor trigger	Single	Double			

Menu 2 - Convenience features

Menu Item	Feature	Opt. 1	Opt. 2	Opt. 3	Opt.4	Opt. 5+
1	One-time Bypass	No Bypass				
2	Nuisance Prevention	On	Off			
3	Valet Switch Pulse Count	1	2	3	4	5
4	Door Trigger Error Chirp	On	Off			
5	Ign-controlled Dome light	On	Off			
6	OEM Alarm Disarm w/Ch2	On	Off			
7	OEM Alarm Disarm Output	With Unlock	Before Unlock	Remote Start Only		
8	OEM Alarm Disarm Pulses	1	2			
9	Aux 1 Output type	Validity	Latch	Latch/reset/ign	Timed 30 secs	Off
10	Aux 1 Linking	No Linking	Link to Arm	Link to Disarm	Link to Arm/disarm	Link to Remote Start only
11	Aux 2 Output type	Validity	Latch	Latch reset/ign	Timed 30 secs	Off
12	Aux 2 Linking	No Linking	Link to Arm	Link to Disarm	Link to Arm/Disarm	Link to Remote Start only
13	Aux 3 Output type	Validity	Latch	Latch reset/ign	Timed 30 secs	Off
14	Aux 3 Linking	No Linking	Link to Arm	Link to Disarm	Link to Arm/Disarm	Smart Key Control (Link to Remote Start Off)

Menu 3 - Remote start features

Menu Item	Feature	Opt. 1	Opt. 2	Opt. 3	Opt.4	Opt. 5
1	Transmission Mode	Manual	Automatic			
2	Engine Checking Mode	Virtual Tach	Voltage	Off	Tachometer	
3	Cranking Time	0.6 sec	0.8 sec	1.0 sec	1.2 sec	1.4 (5)/1.6(6)/ 1.8 (7) 2.0(8)4.0(9)
4	Remote Start Runtime	12 min	24 min	60 min		
5	Activation Pulse Count	1	2			
6	Turbo Mode	No Turbo Mode	On-1 min	On-3 min	On-5 min	On-10min
7	Timer Mode Runtime	12 min	3 min	6 min	9 min	
8	Flex Relay Function	Ignition 2	Accessory 2	Starter 2		
9	Diesel Start Delay	Wait-to Start input	Timed 15 sec	Timed 30 sec	Timed 45 sec	
10	Accessory during Diesel Start Delay	On	Off			
11	Status 2 Output	Status	Latch Rear Defogger	Pulse Rear Defogger		
12	Parking Light Output	Constant	Pulsed	Off		
13	Anti-grind Output	On	Off			
14	Tach Mode Starter Release	Normal	Increase	Decrease		
15	Vehicle temp auto report	Off	On			

Feature descriptions

The features of the system are described below. Features that have additional settings that can be selected only when programming with the Bitwriter® are indicated by the following icon: 

Menu 1 - Security features

Default settings are in bold.

Note: The numbers in parentheses indicate the number of times the LED on the antenna will flash.

1-1 ACTIVE/PASSIVE ARMING: When active arming is selected, the system will only arm when the transmitter is used. When set to passive the system will arm automatically 30 seconds after the last door is closed. To alert the consumer of passive arming, the siren will chirp 20 seconds after the door is closed. This provides the consumer with an audible warning prior to the system actually arming. At the 30 second mark the system will arm but the siren will not chirp.

1-2 PANIC ON: (1 LED flash) This feature controls whether or not the panic mode is available with the ignition ON. In some states there are laws prohibiting a siren sounding in a moving vehicle. This feature makes the system compliant with these regulations. The LED flashes twice (2) to indicate Panic with ignition OFF. When Panic is OFF, the LED flashes (3)

1-3 Arm/disarm and Warn Away CHIRPS ON: (1) This feature controls the chirps that confirm the arming and disarming of the system, Arm/Disarm chirps ON, w/Warn Away chirps OFF (2), Arm/disarm chirps OFF, w/ Warn Away chirps ON (3), Arm/disarm chirps OFF, w/Warn Away chirps OFF (4).

1-4 30 SEC SIREN DURATION:  It is possible to program the unit to sound for 30 or 60 seconds during the triggered sequence. Some states have laws regulating how long a security system can sound. When using the Bitwriter®, the siren can be programmed to sound for any length of time from 1 second to 180 seconds.

1-5 IGNITION LOCKS OFF : (1) When turned OFF the alarm will not lock/unlock the doors when ignition is turned on/off. (2) When turned ON the doors will lock three seconds after the ignition is turned ON and the vehicles doors are closed, and will unlock when the ignition is turned OFF. (3) Lock will only lock the doors three seconds after the ignition is turned ON and the vehicles doors are closed. (4). Unlock only will unlock the doors when the ignition is turned off.

1-6 SINGLE PULSE LOCK/UNLOCK(1): The alarm will send out a single pulse when locking and unlocking. (2) Double-pulse unlock will send out 2 pulses when unlocking. (3) Double-pulse lock will send out 2 pulses when locking. (4) Double-pulse lock/unlock will send out 2 pulses when locking and unlocking.

1-7 0.8 sec DOOR LOCK PULSE (1)DURATION: The default setting is **0.8** second door lock pulses. Some European vehicles, such as Mercedes-Benz and Audi, require longer lock and unlock pulses to operate the vacuum pump. Programming the system to provide 3.5 second (2) pulses, will accommodate the door lock interface in these vehicles. (See door lock connections section for wiring information regarding Type E door locks interfacing. The 0.4 second (3) pulse is required on some vehicles where the lock wires can also control the windows and the 0.8 second pulse will cause the windows to open/close when locking or unlocking.

1-8 No 2nd UNLOCK output (1): The second unlock output is defeated at all times. 2nd unlock ON with ignition control, after first unlock turns on the 2nd unlock output and unlocks the passengers doors after the driver's door is unlocked with ignition controlled locks. (3) 2nd unlock on with ignition control with first unlock will turn on the 2nd unlock output and will unlock the passengers doors at the same time the driver door is unlocked with ignition controlled locks.

1-9 COMFORT CLOSURE OFF(1): The system can be programmed to close the windows when the system is armed. If programmed ON, the lock output provides a 20 second pulse when the system is locked. The output will be cancelled if the unlock button is pressed. In the OFF setting the alarm will not do this function.

(2) Comfort closure 1 - Activates the 20 second timer after the door lock pulse.

(3) Comfort Closure 2 - Activates the 20 second timer with the door lock pulse.

Note: Comfort closure can only be used on cars that have the capability of closing the windows (and on some cars the sunroof as well) with the key cylinder in the door.

1-10 HORN FUNCTION FULL ALARM ONLY (1): SIREN FUNCTION - chirp length 20mS (2) 30mS (3) 40mS (4) 50mS (5). Program for output when the alarm is fully triggered or as the siren (arming/disarming and Warn Away and full trigger with timing options).

1-11 HOOD TRIGGER (normally open): Hood trigger (normally closed). To program the the unit for either a normally open (rests open, or at 12v when the hood is closed) or a normally closed (rests at ground when the hood is closed) pin switch.

1-12 Sensor trigger (single) Sensor trigger double. When programmed on; any 2 sensors (zones 2, 4, 7) need to be triggered within 5 seconds of each other to trigger the alarm. When programmed off; each sensor will trigger the alarm independently.

Menu 2 - Convenience features

Default settings are in bold.

2-1 One time bypass OFF: One time bypass ON. When programmed On the unit will not passively arm for one cycle when turning the ignition on and off within 3 seconds. When going through this procedure the siren will chirp once indicating that One Time Bypass has been activated.

2-2 NUISANCE PREVENTION® CIRCUITRY (NPC) ON: Nuisance Prevention Circuitry OFF. NPC stops repeated triggering of the same zone. If one zone is triggered three times in one hour, that zone is bypassed for one hour, starting from the time of the third trigger. During that hour, if the system sees a trigger on that zone again, the system resets the one hour timer.

If one hour passes and the zone has not triggered again, the zone is activated and can trigger the system again. NPC only monitors sensor inputs, and does not bypass the door trigger or the ignition trigger at any time.

If NPC is turned off, the system will respond to repeated triggers on the sensor inputs and will do so indefinitely. Some states have laws regulating how many times a security system can trigger before it is considered a nuisance and the vehicle is towed away.

2-3 Disarm from valet, 1 pulse. Disarm from valet, 2 - 5 pulses. The system can be programmed to count the number of presses of the valet switch before disarming the security system. The factory default setting is one pulse. The unit can also be set for two to five pulses.

2-4 Door trigger error chirp ON: Door trigger error chirp OFF. This feature controls the error chirp that is generated if the system is armed with the door trigger active. This is useful in vehicles that have a long dome light delay after the door has been closed. If the system is armed before the dome light has turned off, the security system will generate the door trigger error chirp. If this error chirp is not desired, use this feature to disable the door open error chirp. If the error chirp is turned off, no bypass chirp will be generated, even if a door is accidentally left open.

2-5 IGNITION CONTROLLED DOME LIGHT SUPERVISION ON: If turned on, the system will turn on the dome light for 60 seconds when the ignition is turned off. The optional dome light supervision feature must be installed as described in the Wire Connection Guide. Use the two-chirp setting for: Ignition controlled dome light OFF.

2-6 FAD w/channel 2 ON: FAD w/channel 2 OFF. In the default setting the factory alarm disarm output will disarm the factory alarm system any time the button controlling the trunk release output is pressed.

2-7 FACTORY ALARM DISARM-WITH UNLOCK, BEFORE UNLOCK, REMOTE START ONLY: In the default setting the factory alarm disarm output will disarm the factory alarm system any time the button controlling Unlock or Remote Start is pressed. The “Before Unlock” output will disarm the factory alarm before the unlock output activates and when remote start is activated. The “Remote Start Only” will disarm the factory alarm only when the remote start is activated.

2-8 FAD 1 pulse: FAD 2 pulses. This setting determines how many pulses the security system will output on the Factory alarm disarm wire.

2-9 Channel 1 Validity (1) Latched (2), Latch reset w/ignition (3), 30-sec. timed (4)

■ **Validity:** Output that will send a signal as long as the transmission is received.

■ **Latched:** Output that will send a signal when the Channel 1 button(s) is pressed and will continue until the same button(s) is pressed again.

■ **Latched, reset with ignition:** Similar to the latched output this output type turns ON the first time the Channel 1 button (s) is pressed and turns OFF the next the same button is pressed. This output type additionally stops and resets whenever the ignition is turned ON, and then OFF.

■ **30-second timed:** Output that will send a continuous signal for 30 seconds.

■ **Off:** Output is disabled.

Note: All auxiliary channel timed outputs can be programmed using the Bitwriter® (1-90 seconds)

2-10 Channel 1 Linking, None (1) Arm (2) Disarm (3) Arm/Disarm (4) Remote Start (5). When programming to Validity or timed output this can be programmed to activate when arming or disarming (or remote start) with the transmitter.

2-11 Channel 2 Validity (1) Latched (2), Latch reset w/ignition (3), 30-sec. timed, (4) Output, (5) Off: Channel 2 can be programmed for these output configurations. The unit is set to the default validity output. To change the configuration use the two-chirp setting to toggle through the different configurations. Refer to feature 2-9 for additional details.

2-12 CHANNEL 2 Linking None (1) Arm (2) Disarm (3) Arm/Disarm (4) Remote Start (5). Refer to feature 2-10 for additional details.

2-13 CHANNEL 3 Validity (1) Latched (2), Latch reset w/ignition (3), 30 -sec. timed, (4) Output, (5) Off: Channel 3 can be programmed for these output configurations. The unit is set to the default validity output. To change the configuration use the two-chirp setting to toggle through the different configurations. Refer to feature 2-9 for additional details.

2-14 CHANNEL 3 Linking None (1) Arm (2) Disarm (3) Arm/Disarm (4) Smart key control (link to remote start Off) (5). When channel 3 is programmed to Smart Key control, this wire outputs a 800ms pulse when the remote start is shut off.

The alarm also monitors the door trigger input so when the door is opened during the remote start runtime, the remote start shuts down and this wire outputs the 800ms pulse.

Note: This wire is connected to the wire at the push button that start/stops the car. It pulses the wire at the button to shut off the car when the remote start is deactivated.

Menu 3 - Remote start options

Default settings are in bold.

3-1 MANUAL TRANSMISSION MODE: This is the default setting. The two-chirp setting is used for Automatic transmission mode. In the default setting the remote start unit is programmed to look for a shutdown procedure to activate the remote start.

3-2 ENGINE CHECKING VIRTUAL TACH: (1) When set to “virtual tach” the remote start will monitor the cranking voltage of the vehicle and set that voltage as a reference point. Fifteen seconds after the crank output sequence the remote start checks the voltage again to determine if the vehicle is running.

When set to voltage, the unit cranks the starter for the programmed time and then attempts to sense that the engine is running by detecting an increase in voltage. When set to Tachometer, the unit references the learned tach signal to disengage the starter. In addition it will monitor the RPM and shut down if the engine RPM is too high or too low.

Note: The tach wire must be connected and programmed for the manual transmission mode to work.

3-3 CRANK TIME 0.6 0.8 (2) 1.0 (3) 1.2 (4) 1.4 (5) 1.6 (6) 1.8 (7) 2.0 (8) 4.0 (9) SECONDS: If the unit is programmed for no engine checking or voltage sense, the crank time must be set to the appropriate duration. The default setting is 0.6 second and the LED will flash once. If a different crank time is desired, toggle through the higher settings by using the two-chirp settings.

Note: The numbers in parentheses indicate the number of times the LED will flash.

3-4 RUN TIME 12 (1), 24 (2) 60 (3) MINUTES:  Selects the time in minutes that the system will operate the engine until the system “times out”. The system may be shut down using the remote or any of the shutdowns at any time. Using the Bitwriter®, the run time can be programmed for any duration from 1-60 minutes.

3-5 ACTIVATION PULSE ONE: This allows the system to use 1 or 2 pulses to activate the remote start sequence. The default setting is 1-pulse.

Note: This setting affects both the input wire and the remote control.

3-6 TURBO MODE: OFF The factory default is OFF. ON - 1 min (2), 3 (3) 5 (4) 10 (5) MINUTES: There are two ways that “turbo timer mode” can be activated, one by remote and the other manually.

To activate by remote the vehicle needs to be running. Press the **f** button on the remote two times and then press  the remote start button. When you receive a confirmation tone on the remote you can turn off the ignition, and the car will remain running.

To activate manually a push button needs to be hardwired to the (-) activation input on the remote start unit. When the vehicle is running press the button the appropriate amount of times to activate the remote start (factory setting is for 1 pulse). The remote emits a confirmation tone. You can then turn off the ignition and the car will stay running for the pre programmed amount of time.

Note: For this feature to work the “turbo timer run time” mode needs to be programmed ON and the tachometer wire on the remote start needs to be connected and programmed.

3-7 TIMER MODE RUN TIME—12min (1),  This is the default setting. Selects the time in minutes that the system will operate the engine until the system "times out" when the remote start activates in timer mode. Use the two-chirp setting for 3(2), 6 (3), 9 (4) MINUTES: This is the maximum operation period and the system may be shut down using a shutdown at any time. Using the Bitwriter®, the run time can be programmed for any duration from 1-16 minutes.

Note: The numbers in parentheses indicate the number of times the LED will flash.

3-8 FLEX RELAY FUNCTION: Ignition 2 (1) In the factory setting, the flex relay will function the same as the pink ignition 1 wire, in accessory setting the flex relay will function the same as the Orange accessory 1 wire, in starter setting the flex relay will function the same as the purple starter 1 wire.

3-9 DIESEL TIMER—WAIT-TO-START INPUT - Timed 15, 30, **45 SECONDS:**  Default is the “Wait-to-Start” input control wire, or programmable to ignore the input control wire by a delay of 15 (2), 30 (3), or 45(3) seconds. This feature can also be optionally programmed with the Bitwriter®, with a delay from 1 to 90 seconds.

Note: The numbers in parentheses indicate the number of times the LED will flash.

3-10 ACCESSORY STATE DURING WAIT-TO-START ON: This feature will allow the selection of the accessory output to be ON or OFF during wait-to-start. Use the two-chirp setting for OFF.

3-11 2nd STATUS OUTPUT: NORMAL: This feature will allow selection of status output or a rear defogger mode that turns on ten seconds after the vehicle has started if the vehicle interior temperature is below 55 degrees F. The defogger mode has two selections, latched, the LED will flash twice, or pulsed, the LED will flash three times. Latched mode will only stay on for 10 minutes.

Note: When the defogger mode is on, the output will always be active and can be turned on independently with the remote for a one-time activation. (See the Remote Functions table.)

3-12 PARKING LIGHTS CONSTANT: In the default setting, the parking lights (if connected) will come on solid during the remote start runtime. In the two- flash setting the parking lights will flash during the remote start runtime. In the OFF setting, the parking lights will **not** come ON or flash, when the vehicle is remote started.

3-13 ANTI-GRIND ON: With the anti-grind On (default) the ground-when-armed output will be active during remote start operation. This activates the starter kill relay and prevents the customer from re-cranking the car with the key, when doing key takeover. If accessories such as a voice module or window module are added to the unit, it may be necessary to use the two-chirp setting to program this feature OFF.

3-14 TACH MODE STARTER RELEASE: Normal: Use the two-chirp setting to increase time by 15% of the original tach programmed time. The LED will flash twice (2). To decrease by 15% of the original programmed time, the LED will flash three (3) times.

3-15 Vehicle temperature auto report ON or OFF. The default setting is OFF. When programmed ON the main unit will store the interior temperature of the vehicle in its temporary memory. When the vehicle's interior temperature changes 1 degree celsius, the main unit automatically sends the interior temperature message to the remote and the LED's light up accordingly to display the current temperature. (See Owner's Guide for temperature description.)

Bitwriter® features

The Bitwriter®  has the ability to fine tune certain features of the security system. These features and the adjustments that may be programmed are described in the table below.

Feature	Default setting	Optional settings
Siren duration	30 seconds	1- 180 seconds
Channel 3 timed output	30 seconds	1-90 seconds
Channel 4 timed output	30 seconds	1-90 seconds
Channel 5 timed output	30 seconds	1-90 seconds
Diesel start timer	15 seconds	1-90 seconds
Timer mode run time	12 minutes	1-16 minutes
Timer mode starts	6 starts	1/2/3/4/ 6 /8/10/12/14/16/18/20/22/24 (Starts)
Timer mode intervals	3 hours	1/2/3/4/6/8/10/12/14/16/18/20/22/24 (Hours)
Smart start low temp	0 (F)	OFF/-20/-10/ 0 /10/20/30/40/50/60/70 (F)
Smart start high temp	100 (F)	OFF/40/50/60/70/80/90/ 100 /110/120/130 (F)
Smart start low battery	10.5 volts	OFF/12.5/12/11.5/11/ 10.5 /10/9.5/9 volts
Sensor 1 level	7 (normal)	0/1/2/3/4/5/6/ 7 /8/9/10/11/12/13/14/15
Starter release fine tune	10 (normal)	0/1/2/3/4/5/6/7/8/9/ 10 /11/12/13/14/15/16/17/18/19/20
Feature programming	Unlocked	Locked
Transmitter programming	Unlocked	Locked
Remote start runtime	12 minutes	1-60 minutes

Nuisance prevention circuitry

NPC requires that you change the way you test the system since NPC will bypass an input zone for 60 minutes. If the system “sees” the same zone trigger three times, and the triggers are spaced less than an hour apart, the system will bypass that input zone for 60 minutes.

If that zone does not attempt to trigger the system during the 60-minute bypass period, the zone’s monitoring begins again at the end of the hour. If it does attempt to trigger while bypassed, the 60-minute bypass starts over again.

Disarming and rearming the system does not reset NPC. The only way to reset NPC™ is for the 60 minutes to pass without a trigger, or for the ignition to be turned on. This allows the system to be repeatedly triggered, disarmed and re-armed, and still allow NPC to bypass a faulty zone.

When disarming the system, 5 chirps indicate NPC is activated. The LED will report the zone that has been bypassed. (See Diagnostics section of this guide.)

Valet mode

To enter or exit valet mode with the valet/program switch:



1. Turn the ignition key on and then off.

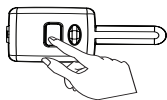

2. At anytime during the next 10 seconds, press and release the Valet switch. Now the Status LED will light constantly if you have entered Valet® Mode, and go out if you have exited Valet Mode.

To enter or exit Valet mode with the remote control:

1. Open any door.

Press **f** two times, and then **🔒** to put the alarm into/out of Valet Mode. The disarm LED flashes and the remote beeps once indicating entry into Valet mode. Repeating the process takes the alarm out of Valet Mode. The disarm LED flashes and the remote beeps twice.

Note: The security system's LED will come on solid when in Valet Mode and will shut off when exiting Valet Mode.

When locking the system in Valet Mode, the Lock and Function LEDs light for one second and emit an error tone. When unlocking in Valet Mode, the Lock and Function LEDs light for one second and emit 2 error tones.

Manual transmission remote start

If the vehicle has manual transmission the proper steps must be followed before leaving the parked vehicle or the remote start feature is disabled.

1. Make sure the doors on the vehicle are closed.
2. Put the transmission in neutral.
3. Press on the brake in the vehicle.
4. Apply the emergency brake.
5. Release the brake.
6. Within 15 seconds activate the remote start from the remote.
7. The parking lights will flash confirming that the remote start is active.
8. Turn off the ignition (the car should stay running when key is turned off).
9. Exit the vehicle.
10. Arm the alarm (the vehicle should shut off when arming the system).

You can now remote start the vehicle. If a door is opened or if the alarm is triggered before the next remote start activation the system will not remote start.

Note: To enable Valet take-over with a manual transmission, open the door and enter into manual transmission mode, as described above. Once you exit the vehicle you can arm the alarm and the car will stay running. If the vehicle shuts down when arming, then the unit did not enter valet take-over mode.

Timer Mode

This unit can be programmed to start and run the engine every three hours, for a maximum of six cycles. The engine will run for the programmed run time and then shut down. After three hours, the system will restart the engine.

Important! Timer Mode should be used only in open areas. Never start and run the vehicle in an enclosed space such as a garage or carport.

To enter or exit timer mode with the transmitter:

1. Remote start the vehicle by pressing **f** twice and then press .
2. The parking lights will flash rapidly four times.
3. After 1 second the car will start and the timer mode will run for the specified time period.

The engine may run for its programmed run time, or the transmitter can be used to shut down the engine. Either way, the remote start system will restart the engine again in three hours. Timer Mode is exited automatically after the sixth run cycle.

The same procedure may be used to enter or exit Timer Mode using the remote transmitter and will slowly flash the parking lights 4 times when exiting.

To exit timer mode manually:

1. Make sure the remote start system is not operating the engine.
2. Turn the ignition on.

Timer Mode will be exited and the parking lights will flash slowly four times.

To enter turbo timer mode with a manual transmission:

Perform the manual transmission procedure (See p.78), **with the door open**. Transmit the timer mode feature with the remote by pressing **f** two-times, and then . After exiting the vehicle, arm the alarm and the vehicle will remain running for the programmed runtime. (The remote start feature is still enabled).

Note: The Bitwriter can change the amount of times the remote start will activate and the intervals between activations in timer mode.

Long term event history

The system stores the last two full triggers in memory. These are not erasable. Each time the unit sees a full trigger, the older of the two triggers in memory will be replaced by the new trigger. To access long term event history:

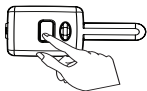

1. With the ignition off, press and hold the Valet/Program switch.



2. Turn on the ignition.

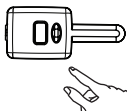

3. Release the Valet/Program switch.

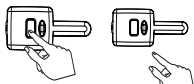

4. Press and release the Valet/Program switch within 5 seconds. The LED will flash in groups indicating the last two zones that triggered the unit for one minute or until the ignition is turned off. Refer to table of zones.

Note: The Warn Away triggers are not stored to memory and will not be reported.

Table of zones

When using the Diagnostic functions, use the Table of Zones to see which input has triggered the system. It is also helpful in deciding which input to use when connecting optional sensors and switches.

ZONE NO.	TRIGGER TYPE	INPUT DESCRIPTION
1	Trunk Input	BLUE (H1/7)
2	Shock Sensor	Onboard shock sensor
3	Door Trigger	GREEN (H1/8) and VIOLET (H1/6).
4	Sensor 2	Optional MUX sensor port
5	Ignition	Heavy gauge pink of remote start harness
6	Hood Trigger	GRAY on the 6-pin shutdown harness.

Note: The WarnAway® response does not report on the LED

Shutdown diagnostics

To perform shutdown diagnostics

1. With the ignition OFF, press and **HOLD** the Valet/Program switch.
2. Turn the ignition ON and then back OFF while **HOLDING** the Valet/Program switch.
3. Release the Valet/Program switch.
4. Press and release the Valet/Program switch. The LED starts flashing to report the last shutdown for one minute or until the ignition is turned on, as shown in the following table:

LED Flashes	Shutdown Mode
1	Runtime expired
2	Over-rev shutdown
3	Low or no RPM
4	Transmitter shutdown (or optional push button)
5	(+) Brake shutdown
6	(-) Hood shutdown
7	Timer mode/Turbo mode/Manual mode error *
8	Neutral safety shutdown
9	Low battery (voltage mode)
10	Alarm triggered **
11	Wait-to-start input timed out

*Timer mode error: Ignition is on or shutdown input is active when activating timer mode.

Turbo mode error: Turbo mode is programmed off, engine is not on or shutdown input is active.

Manual mode error: MTS mode not enabled.

** Alarm was triggered during remote start sequence.

Remote starting diagnostics

When the remote start function is activated and emits an error tone; you have the ability to see what the cause of the no-start situation is by counting the amount of flashes of the parking lights from the vehicle.

5 flashes - Brake wire is active

6 flashes - Hoodpin wire is active

7 flashes - Manual transmission mode is enabled and not initialized.

8 flashes - Neutral safety wire has no ground or the neutral safety is Off.

Remote start safety check

Before vehicle reassembly, the remote system must be checked to ensure safe and trouble-free operation. The following test procedure must be used to verify proper installation and operation of the system. The installation must be completed before testing, including connection to the brake switch and hood switch.

1. Test the BRAKE shutdown circuit: With the vehicle in Park (P), activate the remote start system. Once the engine is running, press the brake pedal. The engine should shut down immediately. If the engine continues to run, check the brake circuit connection.
2. Test the HOOD PIN shutdown circuit: With the vehicle in Park (P), open the hood. Activate the remote start system. The vehicle should not start. If the starter engages, check your hood pin and connections.
3. Test the NEUTRAL SAFETY shutdown circuit.

Important! Make sure there is adequate clearance to the front and rear of the vehicle before attempting this test.

1. Make sure the hood is closed and no other shutdown circuits are active.
2. Set the emergency brake.
3. Turn the ignition key to the run position but do not start the engine.
4. Put the vehicle in Drive (D).
5. Put your foot over the brake pedal but do not press down on it. Be ready to step on the brake to shutdown the remote start system.
6. Activate the remote start system.

■ If the starter engages, immediately step on the brake to shut down the system. If it does engage, recheck the neutral safety input connection. The vehicle may use a mechanical neutral safety switch. (See H3/1 BLACK/WHITE neutral safety switch input in *Remote Start Harness Wire Connection Guide* section of this guide.)

■ If the starter does not engage, the test is complete. Once the system passes the three tests, the vehicle can be re-assembled and delivered. Do not use the remote start system or finalize the installation if it fails any of the safety check tests.

Troubleshooting

Alarm

■ Shock sensor doesn't trigger the alarm:

Has the NPC® system been triggered? If so, you will hear 5 chirps when disarming. To check this, turn the ignition key on and off to clear the NPC®'s memory, and then retest the shock sensor. For a detailed description of NPC®, see Nuisance Prevention Circuitry section of this guide.

■ Door input does not immediately trigger full alarm. Instead, chirps are heard for the first 3 seconds:

That's how the progressive two-stage door input works! This is a feature of this system. This is an instant trigger, remember, even if the door is instantly closed again, the progression from chirps to constant siren will continue.

■ Closing the door triggers the system, but opening the door does not:

Have you correctly identified the type of door switch system? This happens often when the wrong door input has been used. (See Door Lock Harness Wire Connection Guide section of this guide.)

■ System will not passively arm until it is remotely armed and then disarmed:

Are the door inputs connected? Is the H1/6 blue wire connected to the door trigger wire in the vehicle? Either the H1/5 green or the H1/7 violet should be used instead. (See wiring diagrams.)

■ Door input does not respond with the progressive trigger, but with immediate full alarm:

Does the Status LED indicate that the trigger was caused by the shock sensor? (See Diagnostics section of this guide.) The shock sensor, if set to extreme sensitivity, may be detecting the door unlatching before the door switch sends its signal. Reducing the sensitivity can solve this problem.

■ **The Valet/Program switch doesn't work.**

Is it plugged into the correct socket? See Plug-In LED and Valet/Program Switch section of this guide.

■ **Status LED doesn't work.**

Is it plugged in? (See Plug-In LED and Valet/Program Switch section of this guide.) Is the LED plugged into the correct socket?

■ **Door locks operate backwards.**

This unit has easily-reversed lock/unlock outputs. Recheck wire connections to see if you have reversed these.

Remote start

■ **The remote start will not activate.**

1. Check remote startup diagnostics to determine what may be the cause of the no start situation.
2. Check the harnesses and their connections. Make sure that the harnesses are completely plugged into the remote start module. Make sure there are good connections to the vehicle wiring.
3. Check voltage and fuses on the main 12-pin harness and on the heavy gauge remote start harness.

■ **The remote start will activate, but the starter never engages.**

1. Check for voltage on the purple starter wire two seconds after the remote start becomes active. If there is voltage present, skip to Step 4. If there is not voltage present, advance to Step 2.
2. Check the 30A fuses.
3. If the gray/black wait-to-start wire is detecting ground upon activation, the starter will not crank.
4. Make sure the purple starter wire is connected on the starter side of the optional starter kill/anti-grind relay.
5. Does the vehicle have an immobilizer? Some immobilizer systems will not allow the vehicle to crank if active.

6. Check connections. The heavy gauge remote start input wires on the heavy gauge 10-pin connector should have a solid connection. "T-taps" or "scotch locks" are not recommended for any high current heavy gauge wiring.

■ The vehicle starts, but immediately dies.

1. Does the vehicle have an immobilizer? The vehicle's immobilizer will cut the fuel and/or spark during unauthorized starting attempts.
2. Is the remote start programmed for virtual tach voltage sense? If so, the crank time may not be set high enough. Voltage sense will not work on some vehicles.
3. Check diagnostics. Sometimes a shutdown will become active during cranking or just after cranking.

■ The vehicle starts, but the starter keeps running.

1. Is the system programmed for engine checking off or virtual tach voltage sense? When programmed for either of these features, the engine cranks for the preprogrammed crank time regardless of how long it takes for the vehicle to actually start. Adjust to a lower cranking time.
2. Was the Tach Learn successful? The LED must light solid and bright to indicate a successful learn.
3. Make sure that there is a tach signal at the purple/white tach input wire of the remote start. If there is not a tach signal, recheck the connection to the vehicle's tach wire and make sure the wire is not broken or shorted to ground leading to the remote start.

■ The vehicle will start, but will only run for 10 seconds.

1. Is the remote start programmed for voltage sense? If this does not work, a tach wire should be used.
2. Check diagnostics.

■ The climate control system does not work while the unit is operating the vehicle.

Either the wrong accessory wire is being energized or more than one ignition or accessory wire must be energized in order to operate the climate control system.

Responder LE Quick Reference Wiring Guide

For connecting to external modules

D29 Jumper must be horizontal for switch external module.



Access Door Fuse Jumper under door. Use needle nose pliers to change fuse position.

Antenna four pin connector

- Red/White aux trunk release (-) 200mA
- Red 12V (+) constant input
- Brown siren (+) output
- White/Brown Flex parking light relay 37A
- Black chassis ground
- Violet door (+) input
- Blue trunk (-) instant trigger input
- Green door (-) input
- Black/white domelight 200mA (-) output
- White/Blue remote start activation (-) input
- White parking light output 30
- Orange ground-when-armed (-) 500mA output

H3

- Pink Ignition 1 (+) output (also ignition sense input)
- Red/white fused 30a (contact 87 of RS Flex Relay)
- Orange accessory output
- Violet starter output (car side of starter wire)
- Green starter input (key side of starter wire)
- Red 12V (+) constant fused 30a input (for ignition relay)
- Pink/White Flex Relay output (default is ignition 2)
- Pink/Black Flex Relay output 87a (default is ignition 2)
- Redback fused 30a (for accessory and starter relays)

H1

- Optional Mux sensor port
- Status LED Output (use White two-pin from antenna cable)
- Violet Programs switch input (use Blue two-pin from antenna cable)

Remote start output

Replay start

RS

Door Lock/Unlock

RS

Tech Thwumper Jumper

Bitwriter

ESP

Neutral Safety Switch

Blue/White remote start status (-) 200mA output

Blue/White remote start status (-) 200mA output

Gray hood pin switch NO/NC (-) input

Blue (-) Lock

Green (+) Unlock

Light Green/Black OEM disarm (-) 200mA output

Light Green/White OEM arm (-) 200mA output

White/Black AUX 1 (-) 200mA output

White/Black AUX 2 (-) 200mA output

White/Black AUX 3 (-) 200mA output

Light Blue 2nd Unlock (-) 200mA output

Gray/Black wait-to-start (-) input

Brown/Black (-) 200mA Horn honk output

IMPORTANT! This must be plugged in and in the On position.

ON

New Wires 1 - 4 on the auxiliary output are used for the (-) trigger for the vehicle. The (-) trigger wire must be plugged in to the vehicle place a 1-amp diode in line to prevent feedback from the vehicle.

Blue RS status (-) 200mA output

Pink RS ignition 1 (-) 200mA output

Violet RS starter (-) 200mA output

Pink/White flex (-) 200mA output (default setting is ignition 2)

Heavy gauge 10-pin connection rear view

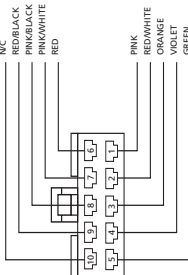

© 2008 Directed Electronics

Designed and Engineered in the USA

Directed[®]
E L E C T R O N I C S

N5202X 2008-02